

TEXEL[®] **Magnetic Drive Pumps**

MTA Series



TEXEL[®]

 **TEXEL-SEIKOW U.S.A., Inc.**

TEXEL MTA pumps are highly reliable, provide excellent corrosion resistance, robustness, and high durability for use across various applications.

TEXEL High pressure transfer molding process

TEXEL's unique high-pressure molding process produces a uniform thickness and smooth surface lining. This is done to prolong the life of the pump. Also, this molding eliminates the gap between the lining of the casing and the cast iron, while preventing the lining from shifting or moving.

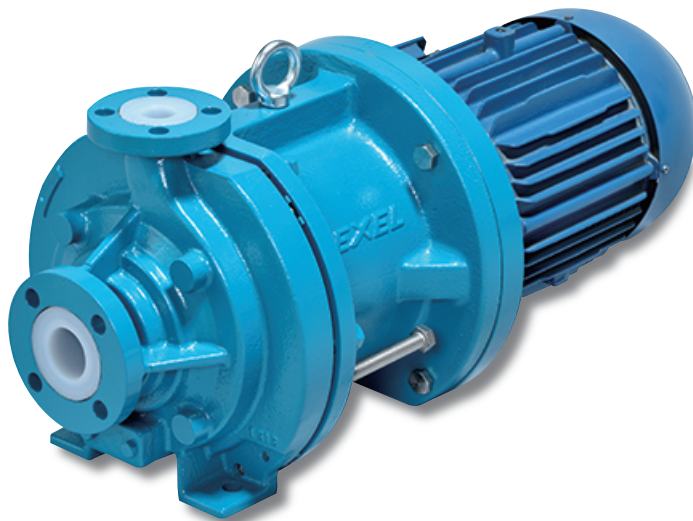

PFA

The main parts of MTA pump such as casing, impeller, and lining are made of PFA, which has excellent characteristics for process pumps.

PFA Lining

The PFA lining of TEXEL MTA pump has a sufficient thickness of 5-6 mm and has excellent corrosion resistance, strength, and abrasion resistance.

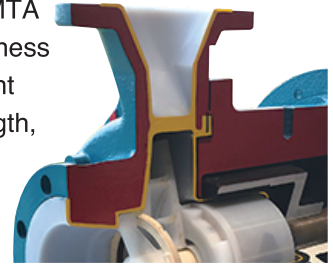

Seamless lining

A completely seamless internal magnet lining prevents magnet corrosion and reduces the possibility of pump failure.

Back-pull structure

TEXEL's unique back pull-out structure allows the main components to be assembled and disassembled individually. During maintenance, disassembly, or inspection, work can be done without removing the discharge / suction pipes. Therefore, it makes parts replacement and maintenance work easier and reduces work time.

Flange

All flange sizes comply with ANSI / ASME B16.5 Pipe Flanges and Flanged Fittings standards.

Features of PFA

High durability and abrasion resistance

It has excellent durability and can be used for a long period of time in severe environments. It has a low abrasion coefficient and excellent lubricity.

Excellent heat resistance

It maintains stable mechanical strength over a wide range of temperatures from low to high temperatures. TEXEL MTA pumps can be used at -4 to +248°F (-20 to +120°C).

Chemical resistance

Highly impervious to chemicals and excellent in corrosion resistance. It reduces the need for maintenance and makes it possible to minimize downtime during operation.

Features of components

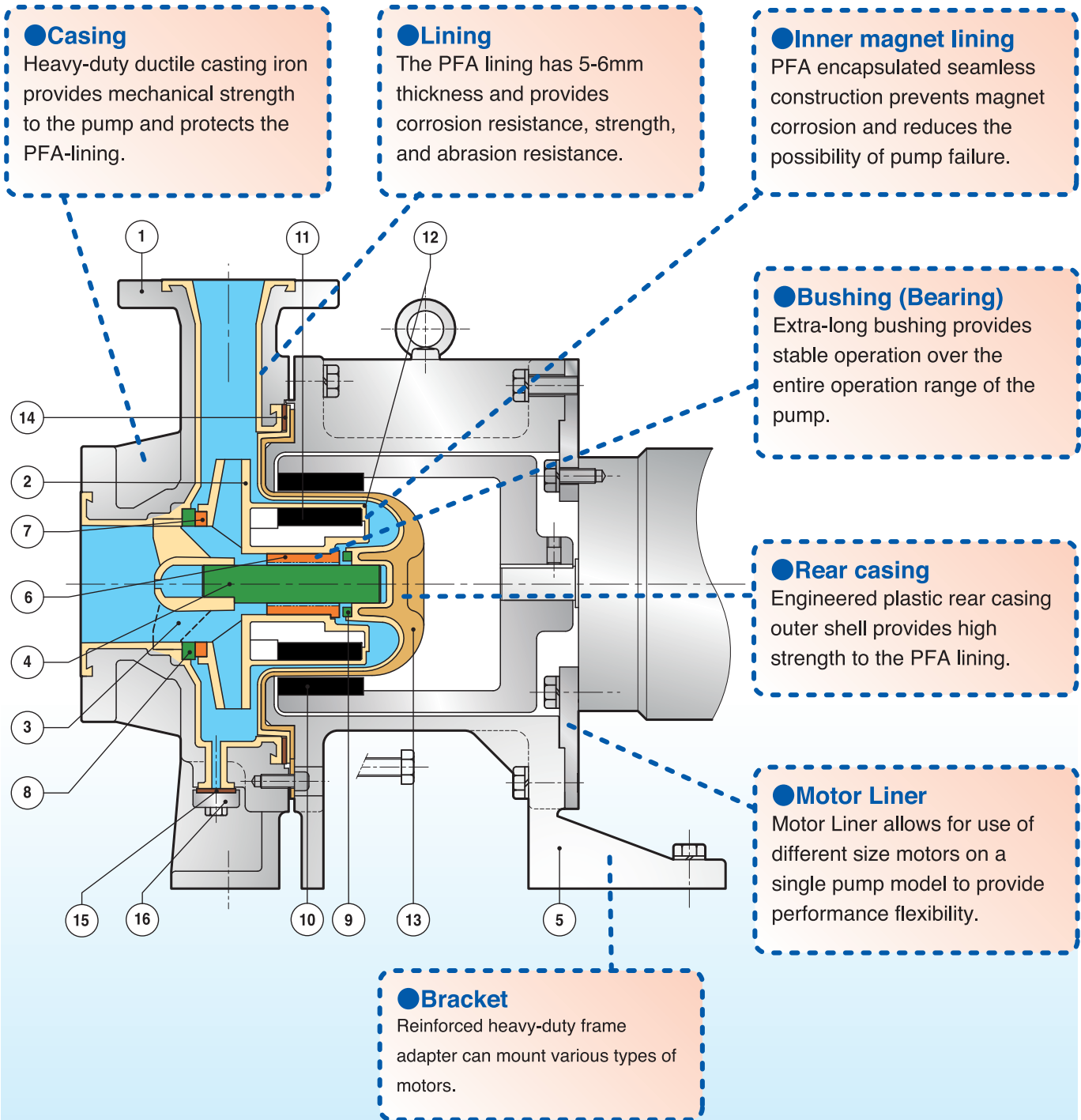

No.	Description	Material
1	Casing	PFA(Wet Side) + Ductile Iron
2	Impeller	PFA
3	Shaft Support	PFA
4	Shaft	SiC (Titanium: Option)
5	Bracket	Cast Iron
6	Bushing	SiC or C-PTFE (Carbon, G-PTFE: Option)
7	Mouth Ring	SiC or C-PTFE
8	Front Thrust Ring	SiC
9	Rear Thrust Ring	SiC

No.	Description	Material
10	Outer Magnet	Rare earth
11	Inner Magnet	Rare earth
12	Magnet Lining	PFA
13	Rear Casing	PFA(Wet Side) + Eng. Plastic C-PVDF (Wet side): Option
14	Casing Gasket	PTFE
15	Drain Gasket	PTFE
16	Drain Flange	Cast Iron or Stainless steel

Composite Capacity Chart & Identification

Capacity Chart

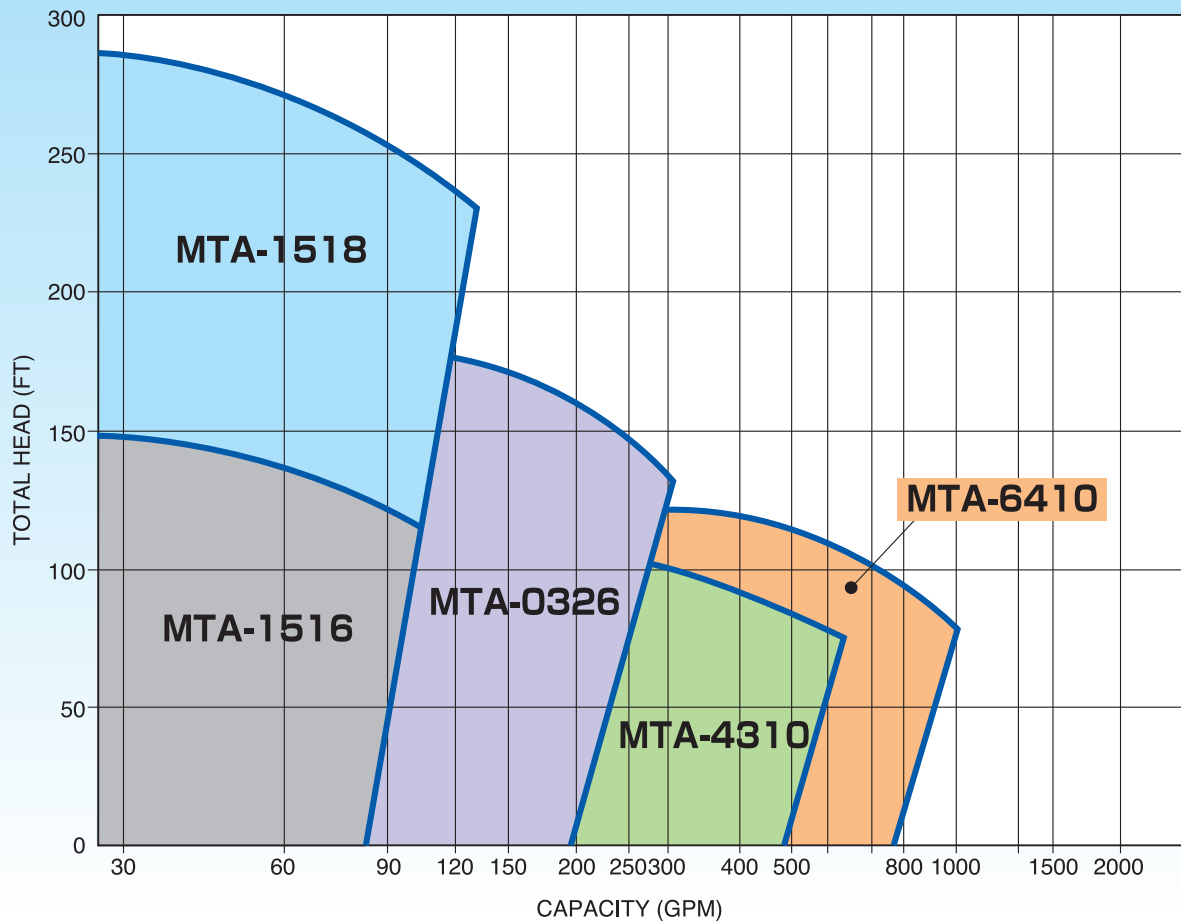

Identification

MTA - 1516 P 02 F E 4
1 2 3 4 5 6 7

1	PUMP SERIES	MTA SERIES				
	MODEL NAME	1516	1518	0326	4310	6410
2	SUCTION SIZE (inch)	1.5	1.5	3	4	6
	DISCHARGE SIZE (inch)	1	1	2	3	4
	NOMINAL IMPELLER DIAMETER	DEPEND ON MODEL				
3	GASKET MATERIAL	P : PTFE	Z : Other			
4	MOTOR OUTPUT	01: 1 HP	02: 2 HP	03: 3 HP	05: 5 HP	07: 7 HP
		15: 15 HP	20: 20 HP	25: 25 HP	30: 30 HP	40: 40 HP
5	PUMP BODY MATERIAL	TYPE	CASING	IMPELLER+INNER MAGNET	REAR CASING	
		F	PFA	PFA	PFA+ENG.PLASTIC	
		Z	OTHER COMBINATION			
6	BEARING COMBINATION	TYPE	SHAFT	FRONT&REAR THRUST	MOUTH RING&BUSHING	
		E	SiC		C-PTFE	
		B	SiC			
		Z	OTHER COMBINATION			
7	MOTOR POLE	ONLY FOR 4 POLE MOTOR				

Dimensions

Model 1516, 1518

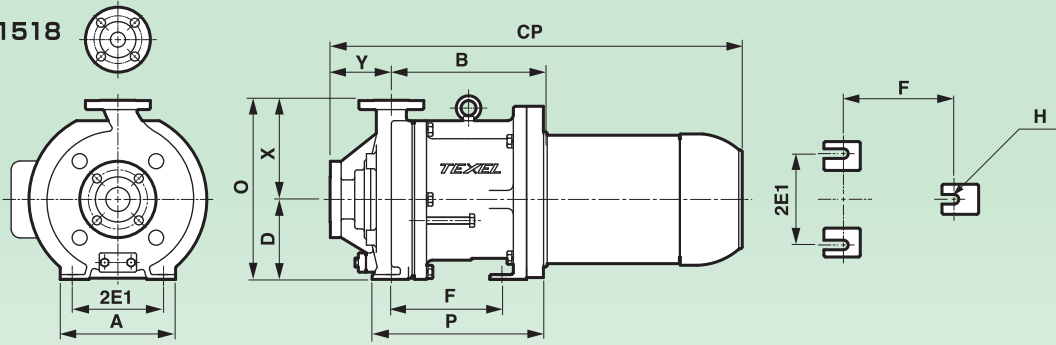

Model 0326, 4310, 6410

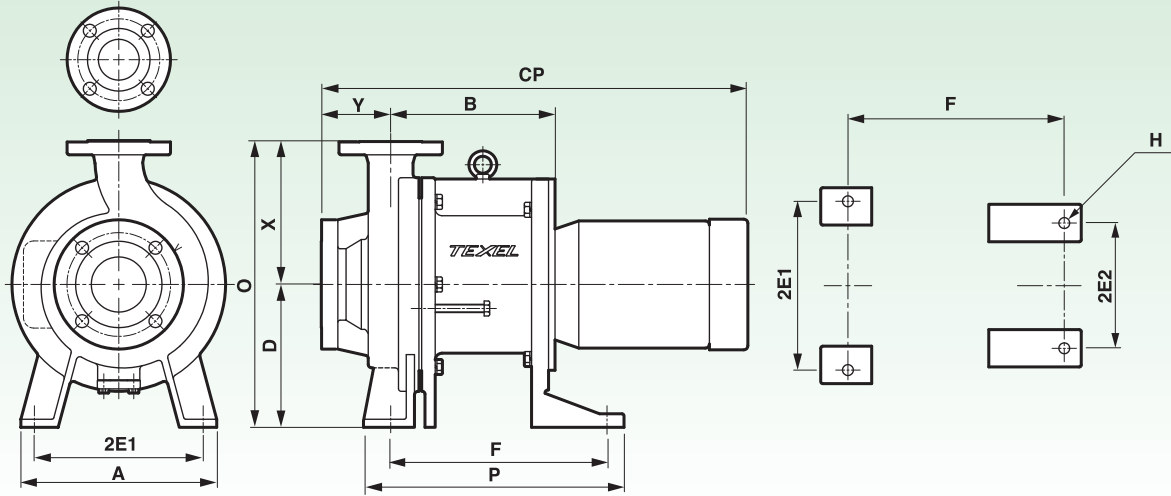

Model	Frame	D	X	O	Y	F	2E1	2E2	A	H	P	CP	B	Weight (lbs)	
1516	143TC & 145TC	5.25	6.5	11.75	4	7.25	6		7.6	φ5/8	10.1		24.4	9.3	170
	182TC & 184TC												26.8	10	
	213TC & 215TC												10.9	10.5	
	254TC & 256TC												21.5	11.1	
	284TSC												39.4	10.4	
1518	143TC & 145TC	5.25	6.5	11.75	4	7.25	6		7.6	φ5/8	10.1		24.4	9.3	170
	182TC & 184TC												25.8	10	
	213TC & 215TC												10.9	10.5	
	254TC & 256TC												21.5	11.1	
	284TSC												39.4	10.4	
0326	143TC & 145TC	8.25	8.25	16.5	4	12.5	9.75	7.25	11.3	φ5/8	15.1		24.4	9.5	240
	182TC & 184TC												26.8	10.2	
	213TC & 215TC												10.9	10.7	
	254TC & 256TC												21.5	11.3	
	284TSC												39.4	10.6	
4310	213TC & 215TC	8.25	11	19.25	4	12.5	9.75	7.25	13.8	φ5/8	16.3		32.3	12.3	430
	254TC & 256TC												36	12.6	
	284TC & 286TC												38.9	13.2	
	324TC												44.4	13.8	
	326TC												46.5		
6410	254TC & 256TC	10	13.5	23.5	4	12.5	9.75	7.25	13.8	φ5/8	16.4		35.9	12.6	550
	284TC & 286TC												39	13.2	
	324TC												44.4	13.8	
	326TC												46.5		

Performance Curve & Technical Data

Pump Specifications

- Operating Temperature : -4 to 248°F
(Please consult us when use at under 32°F)
- Rotation Direction : Clockwise (viewed from the motor)
- Flange : ANSI
- Motor : NEMA
- Finish Paint : Munsell 2.5B4/8,
RAL 5012 Light Blue or equivalent
(pump body)

MTA-1516

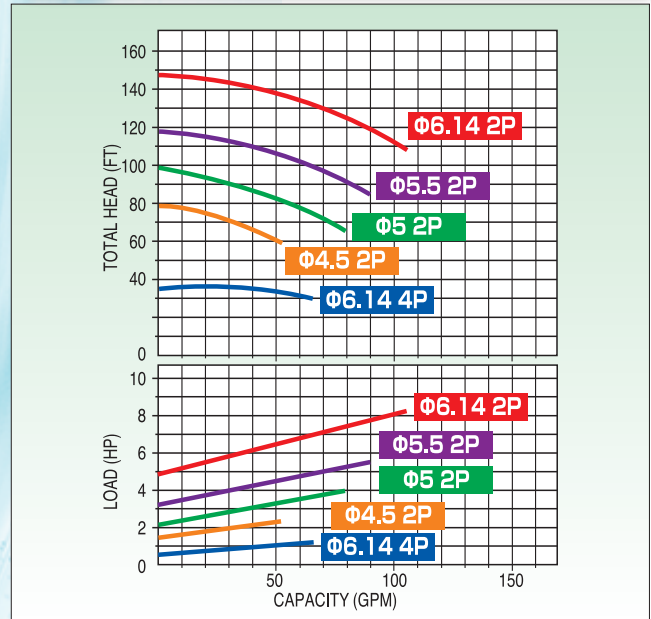

Impeller diameter- Motor pole	Capacity (GPM)	Head (ft)	NPSH Re (ft)	Motor Output
6.14 - 2P	80	125	11.5	2 - 25HP
5.5 - 2P		92		
5 - 2P		65		
4.5 - 2P	40	68	9.8	
6.14 - 4P	40	33	6.9	2, 3, 5HP

MTA-0326

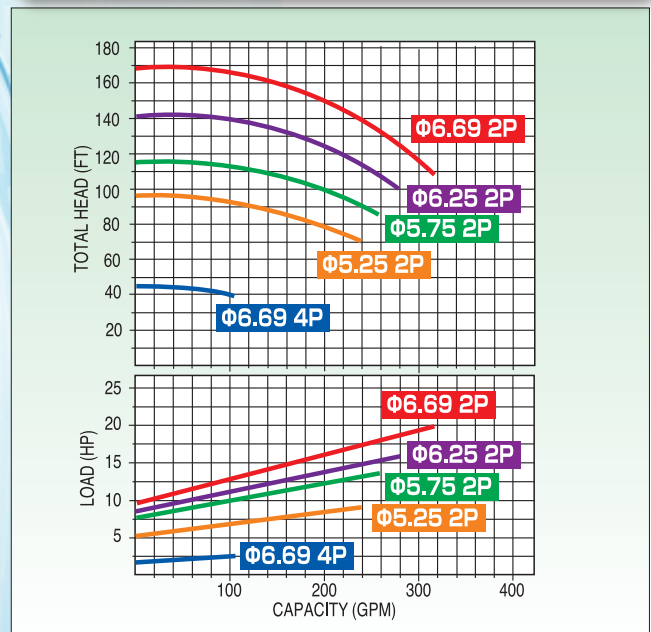

Impeller diameter- Motor pole	Capacity (GPM)	Head (ft)	NPSH Re (ft)	Motor Output
6.69 - 2P	250	155	22.3	2 - 25HP
6.25 - 2P		120		
5.75 - 2P		100		
5.25 - 2P	200	88	17	
6.14 - 4P	105	45	8.5	2, 3, 5HP

MTA-1518

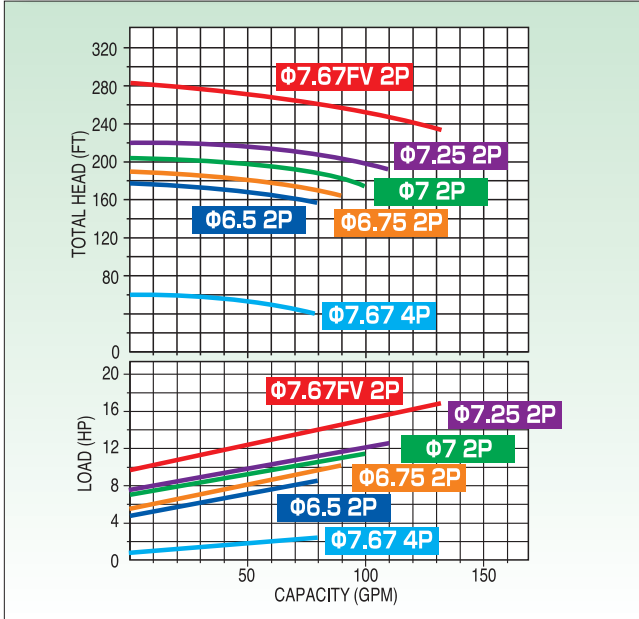

Impeller diameter- Motor pole	Capacity (GPM)	Head (ft)	NPSH Re (ft)	Motor Output
7.67 FV - 2P	80	265	12.2	2 - 25HP
7.25 - 2P		210		
7 - 2P		195		
6.75 - 2P		175		
6.5 - 2P		160		
7.67 - 2P	40	57	6.9	2, 3, 5HP

※FV : Flat Vane Impeller

Necessary Information for Inquiries and Orders

- 1 Total Head : Suction and Discharge (ft)
- 2 Capacity : (GPM)
- 3 Pumping Liquid : Liquid Composition and Density, Operating Temperature, Specific Gravity, Fine Particles, etc.
- 4 Power Source : Voltage, Frequency, Phase

Standard Impeller

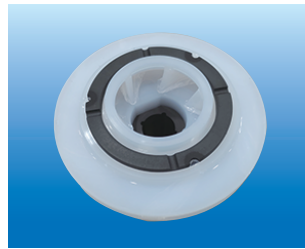

Flat Vane Impeller

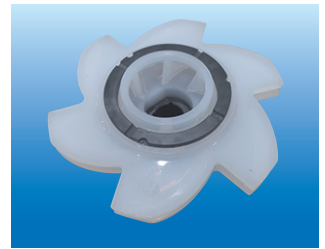

MTA-4310

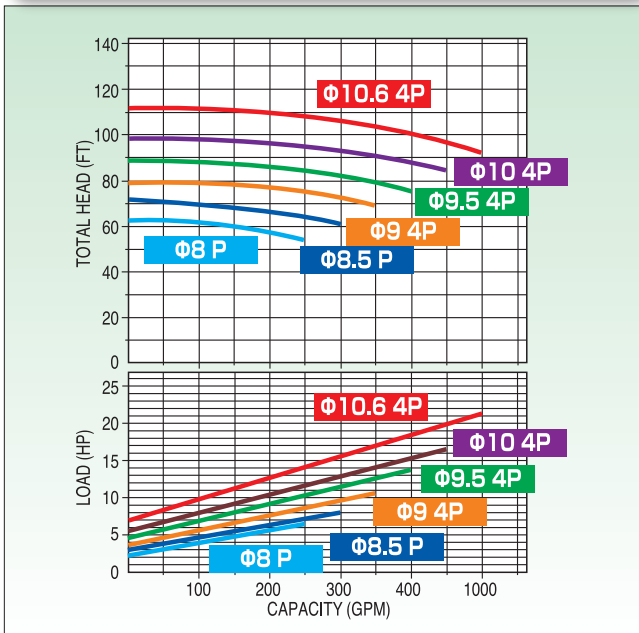

Impeller diameter- Motor pole	Capacity (GPM)	Head (ft)	NPSH Re (ft)	Motor Output
10.59 - 4P	300	105	10.6	7.5 - 50HP
10 - 4P		94		
9.5 - 4P		83		
9 - 4P		73		
8.5 - 4P		68		
8 - 4P	200	60	12	

MTA-6410

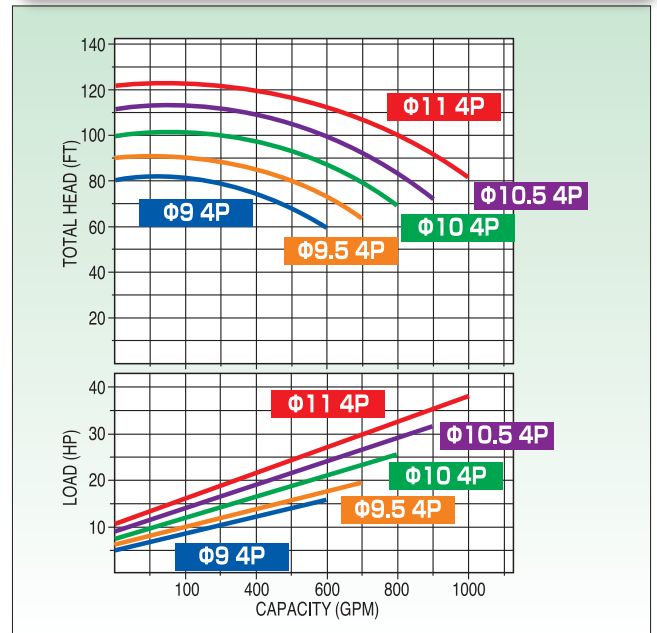

Impeller diameter- Motor pole	Capacity (GPM)	Head (ft)	NPSH Re (ft)	Motor Output
11 - 4P	750	105	11.5	7.5 - 50HP
10.5 - 4P		91		
10 - 4P		75		
9.5 - 4P	500	83	10	
9 - 4P		70		

TEXEL®
 **TEXEL-SEIKOW U.S.A.,Inc.**

4404 W12th St Houston, TX 77055

Office: 713-683-1505 Fax: 713-683-1997

● info@taxelseikowusa.com

● www.texeseikow.com