



TEXEL®

PVDF / ETFE / PFA / PP / GFR-PP Magnetically Driven Pumps



 **SEIKOW CHEMICAL ENGINEERING & MACHINERY, LTD.**

< Contents >

- 02 50Hz · 60Hz Capacity Range
- 03 Pump Materials
- 04 Titanium Inner Magnet
- 05 Solution for Bearing Operation in "Dry State"
- 05 Type Selection Procedure
- 06 Dry-Run Protector
- 07 Corrosion Resistance Table



50Hz Capacity Range

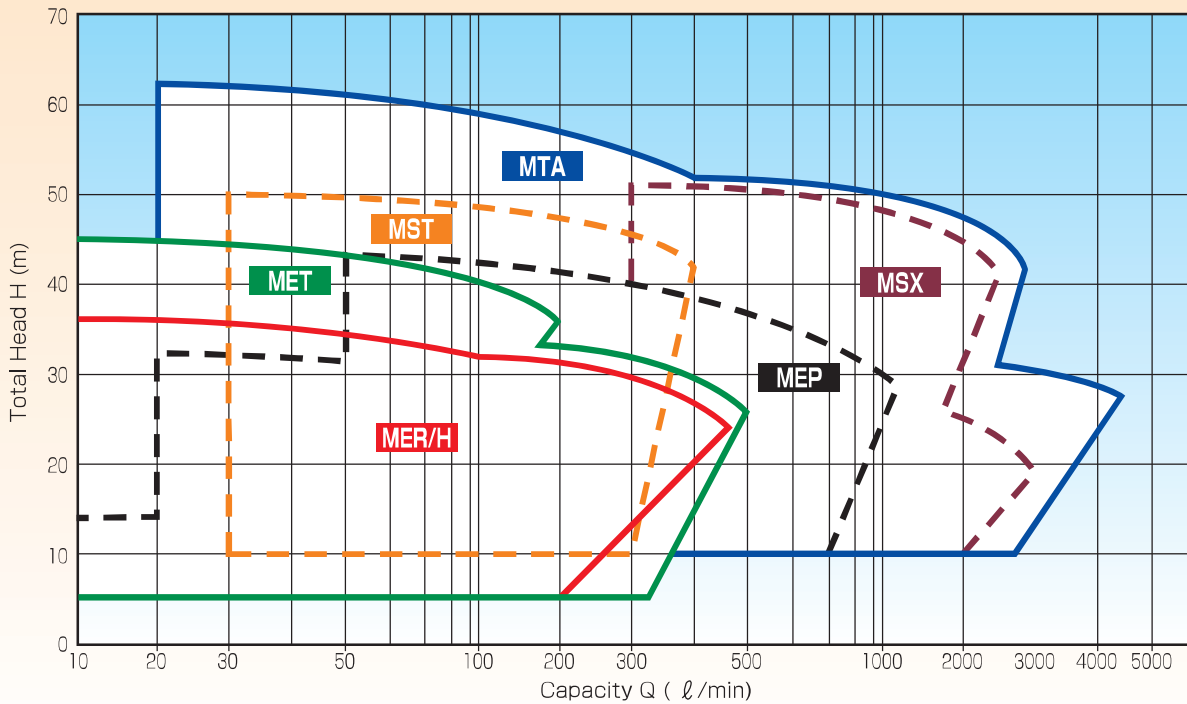

60Hz Capacity Range

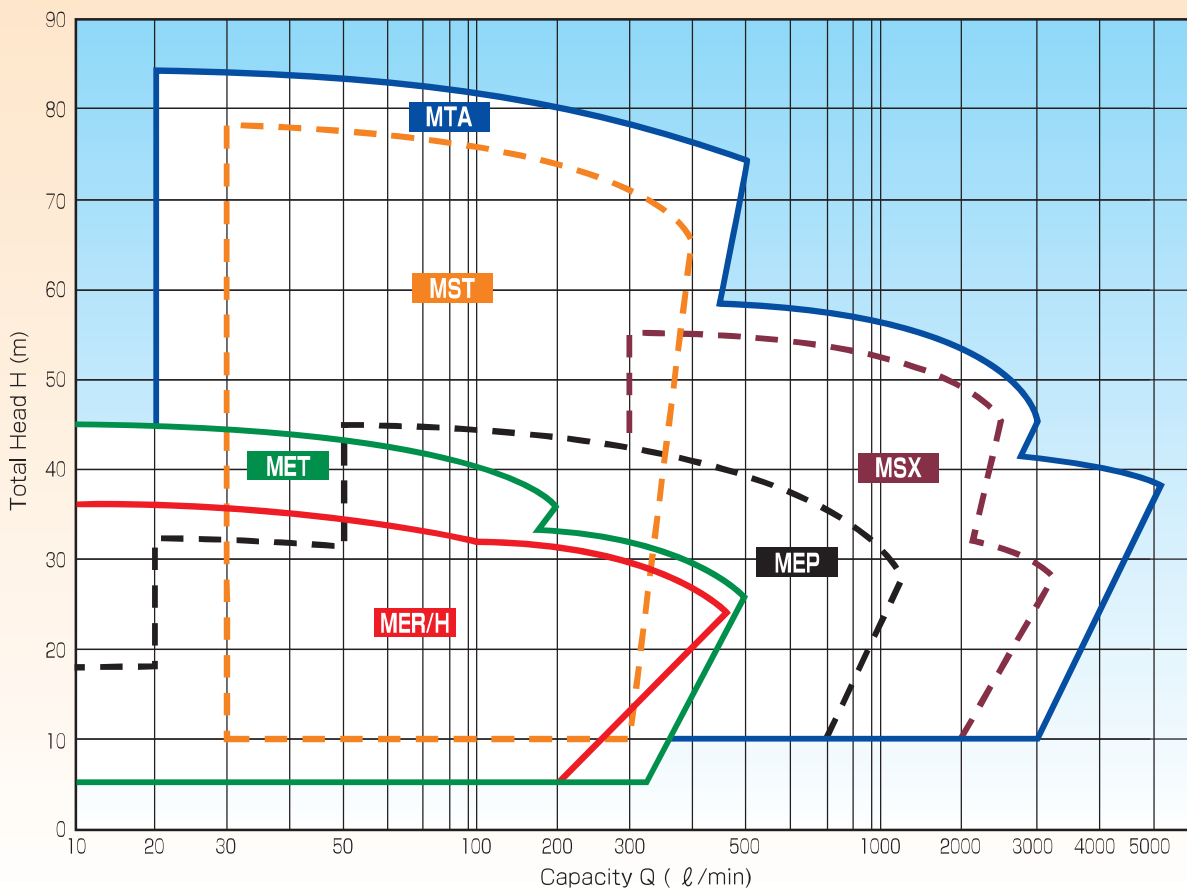

Necessary Information for Inquiries and Orders

- 1. Total Head :** Suction and Discharge (m)
- 2. Capacity :** (l/min)
- 3. Pumping Liquid :** Liquid Composition and Density, Operating Temperature, Specific Gravity, Fine Particles, etc.
- 4. Power Source :** Voltage, Frequency, Phase

MEP Series
MER Series
MEH Series
MET Series
MTA Series
MSX Series
MST Series
MES Series

Materials of Magnetic Drive Pumps

Main Materials (Impeller, Casing, Inner Magnet, etc.)

PFA	MET-040	MET-050	MTA-040·080 100·101 125·150	MST-050	MSX-100 -125 -150
ETFE	MER-051 MEH-040	MET-050 (Only Impeller / Inner Magnet)	MTA-200 (Except Rear Casing)		MSX-150 (Only Casing)
PVDF			Self-Prime MES-050		MSX-150 (Only Impeller)
PP	MEP-040 -050 -080	Self-Prime MES-040			
FRP				Self-Prime MES-080 Rear casing : PFA Impeller : PFA	

Pump Parts Material Combination

Materials Model	Shaft			Bearing				Rear Casing					O-ring				PTFE Gasket	Back Pull Out Design	Semi-Open Impeller
	Alumina	SiC	Titanium	Carbon	C-PTFE	G-PTFE	SiC	G-PP	C-PVDF	C-ETFE	PFA	SiC	FPM	EPDM	AFLAS®	PERFLUOR®			
MEP-040	●			●	●			●					●	●	★	★			
MEP-050	●			●	●			●					●	●	★	★			
MEP-080	●	●		●	●		●	●					●	●	★	★			
MEH-040	●	●	★	●	●	●	●		●	●			●	●	★	★		★	
MER-051	●	●	★	●	●	●	●		●	●			●	●	★	★		★	★
MET-040	●	●	★	●	●	●	●		★		●						●	●	
MET-050	●	●	★	●	●	●	●		★		●						●	●	★
MTA-040		●	★	●	●	●	●		★		●						●	●	
MTA-080		●	★	●	●	●	●		★		●						●	●	
MTA-100		●	★	●	●	●	●		★		●						●	●	
MTA-101	●	●	★	●	●	●	●			●							●	●	
MTA-125	●	●	★	●	●	●	●			●							●	●	
MTA-150	●	●	★	●	●	●	●			●							●	●	
MTA-200	●	●	★		●	●	●		●								●	●	
MST-050		●	★		●	●	●				★	●					●	●	★
MSX-100		●	★		●	●	●			●	●						●	●	
MSX-125		●	★		●	●	●			●	●						●	●	
MSX-150		●	★		●	●	●			●	●						●	●	
MES-040	●			●	●			●				●	●					●	
MES-050	●	●	★	●	●	●	●		●	★		●	●	★	★			●	
MES-080	●	●	★	●	●	●	●		★		●	●	●	★	★	(●)	●	●	

Symbol definition ● : Standard ★ : Option

C-PTFE: Carbon-reinforced PTFE

G-PTFE: Glass Fiber reinforced PTFE

G-PP: Glass Fiber reinforced PP

※MES-080 uses both

O-ring and Gasket.

C-PVDF: Carbon Fiber reinforced PVDF

C-ETFE: Carbon Fiber reinforced ETFE

Characteristics of Fluorocarbon Resin Materials

Fluorocarbon resin surpasses any other plastics in both heat resistance and chemical resistance. The fluorocarbon resins employed in our pumps are PVDF, ETFE and PFA. PFA, with characteristic properties of high corrosion resistance (resistant to various corrosive actions) and high purity, provides the supreme chemical and thermal stability. PVDF and ETFE, with excellent mechanical characteristics and processability, are also superior corrosion resistant materials for pump components although their corrosion resistance is somewhat less than that of PFA.

Basic comparison of fluorocarbon resins is given in the table to the right.

Basic Comparison (for reference only)

Properties		Unit	PTFE	PFA	ETFE	PVDF
Specific gravity		—	2.14~2.20	2.12~2.17	1.70	1.75
Continuous service temperature		℃	260	260	150	150
Tensile break strength		MPa	29	35	49	55
Corrosion resistance	Acid chemical solution		◎	◎	○	○
	Alkaline chemical solution		◎	◎	○	○
	Organic solution		◎	◎	▲	▲

Symbol definition ◎ : Excellent ○ : Good ▲ : Conditional

Codes and names

- PFA: Tetrafluoroethylene - Perfluoroalkylvinylether copolymer
- PVDF: Polyvinylidene fluoride
- ETFE: Ethylene-Tetrafluoroethylene copolymer

Characteristics of Ceramic Materials

The main shaft of our magnetic drive pump is made of alumina ceramic or silicon carbide ceramic. These ceramics, with high-strength, high-modulus and high-heat-resistance characteristics, are perfect materials for pump components. While heat shock fracture is a common concern among ceramic materials, alumina ceramic is resistant up to 180°C of a temperature change and silicon carbide ceramic is resistant up to 500°C.

Ceramics: Physical Properties (for reference only)

Properties	Unit	Silicon carbide ceramic (SiC)	Alumina ceramic (Al ₂ O ₃)
Specific gravity	—	3.1	3.9
Vickers hardness	GPa	21	17
3-point bending strength	MPa	540	380
Coefficient of linear expansion	×10 ⁻⁶ /℃	4.0	7.0

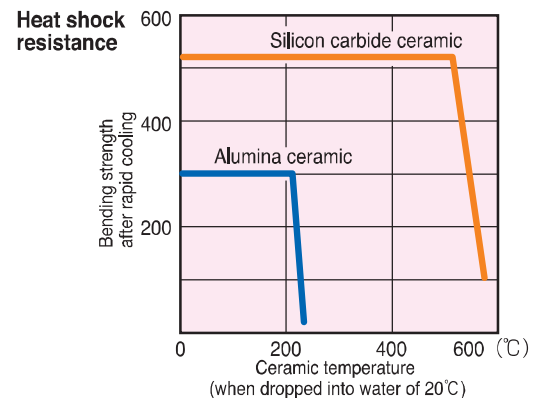
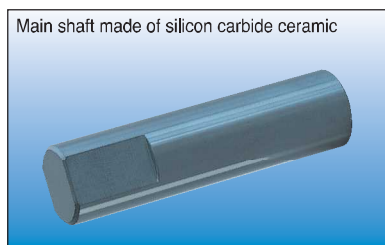

Titanium Inner Magnet

In addition to its corrosion- and heat-resistance characteristics, TEXEL magnetic drive pump is available with another advantageous feature that prevents penetration of chlorine and the like. Titanium main shaft and impeller, according to applications, are also available.

Perfect selection for liquid with a high concentration of chlorine:

While fluorocarbon resins have superior corrosion resistance, saturated salt water electrolyte with a higher concentration of free chlorine has been a formidable case since chlorine penetrates the resin coating of the inner magnet and makes a pump practically unserviceable. Titanium-coated inner magnet is our smart solution to prevent chlorine penetration. The table below shows cases of the penetration in fluorocarbon resin-coated inner magnets in this application.

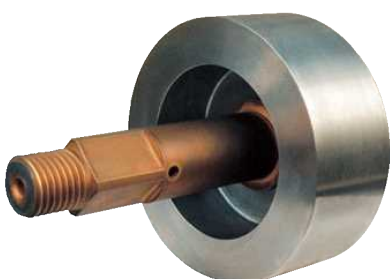

▲Titanium Inner Magnet

Chlorine Penetration in Fluorocarbon Resin-coated Inner Magnet of Magnetic Drive Pump

Extracted from Technical Paper at 1993 National Convention of Electrolytic Soda Manufacturers

PVDF coat	Expanded by penetration in six months
ETFE coat	Expanded by penetration in one month
Coat thickness	3mm

Conditions

Application: Electrolysis of salt water
 Type of salt water: Chlorine contained
 Free chlorine concentration: 2000 ppm
 Temperature: 80°C

Note : No penetration influence on casings was observed in either case.

Solution for Bearing Operation in “Dry State”

Elimination of three major troubles

Idling operation, operation under cavitation and operation with aeration are the three major issues of the magnetic drive pump, which frequently cause damage to the plain bearing of the pump, ending up with a catastrophic failure.

Our analysis has explained these complex problems, resulting in successful improvement of durability of our magnetic drive pumps.

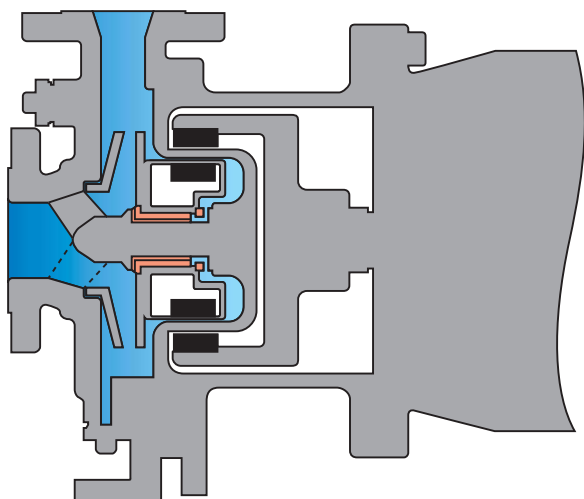

- Carbon material is used for the sliding component.
- The carbon component has exchangeability with the standard component.
- Contact us for applicable chemicals.
- Contact us for further details.

Understanding of three major troubles

These troubles lead to the same result, but each trouble has its particular mechanism especially the condition of the plain bearing inside the pump. Focusing attention on this point, we have achieved extensive improvement.

● Idling operation

Idling operation is an operating state where the pump is not being primed. The impeller has no thrust produced in pumping-up and the plain bearing is completely dry.

● Operation under cavitation

The pump is in pumping-up operation. The plain bearing is in a half-dry state as some of created bubbles get into it through the rear casing. During this operation, the impeller has both axial and radial thrust.

● Operation with aeration

Increased aeration in the pumping operation would disable the pumping operation. It causes changes of the load on the impeller. The plain bearing is in a half-dry state because of aeration by some of created bubbles.

Durability test results

The durability test results of the plain bearing, tested in each operating condition, are given in the table below.

Idling operation	No failure found after 2.5-hour test operation
Operation under cavitation	No failure found after 3-hour test operation at 3% fall of head
Operation with aeration	No failure for 3 hours before pumping-up operation is disabled.

Note: Data are for reference only and are not guaranteed values.

Type Selection Procedure

1 Selection of pump type

Select a pump type that meets your operating frequency, discharge rate and total head, using the frequency-capacity chart.

2 Selection of motor rated power

Read and find the required operating shaft power in the performance curve according to the specific gravity of the handling liquid. For safety purpose, the rated power of the motor used for the pump has to be at least 1.1 times the found shaft power.

3 Selection of material

(Type, concentration and temperature of handling liquid)

Select the materials of the main body and the sliding component based on the type, concentration and temperature of the handling liquid, using the corrosion chart.

4 Checking of NPSH Re

In general, it would be usable if NPSH Av is not less than 1.3 times NPSH Re. Contact us if further details are needed.

5 Checking of operating pressure

The withstanding pressure of the pump varies according to the liquid temperature. Contact and consult us if the liquid temperature is high.

6 Outside dimensions of pump (space required for installation)

See the pump drawing to know the space required for installation.

Note : When installing the back pull-out pump, prepare a space behind the rear end of the pump for the convenience of maintenance.

7 Determination

Determine the pump type based on the above selections and considerations.

Dry-Run Protector



The Texel Dry-Run Protector (DRP), which is controlled by the motor current, requires neither extra accessories for the piping and pump, nor anti-explosion measures, even under hazardous conditions.

By setting the current value during shut-off operation, not only shut-off operation but also dry operation and cavitation can be prevented.

This device is recommended to lengthen the service life of the Texel Magnetic Drive Pump.

The functions of DRP for protecting the pump are as follows:

- 1) Detection of Dry Run (No water in the pump)
- 2) Detection of Not pumping (Liquid has filled the pump)
- 3) Detection of Shut-off running
(Discharge Valve is completely closed)
- 4) Detection of Cavitation
- 5) Detection of Excessive / Inadequate Flow Rate

Standard Specifications

- Power Supply
50/60Hz 100V/115V/200V/230V
Single Phase
- Power Consumption 4W
- Alarm Contact Capacity
1C AC250V 3A
- Ambient Conditions
Temperature : 0~40 °C
Moisture : RH40~85%

Outside Dimensions of the DRP

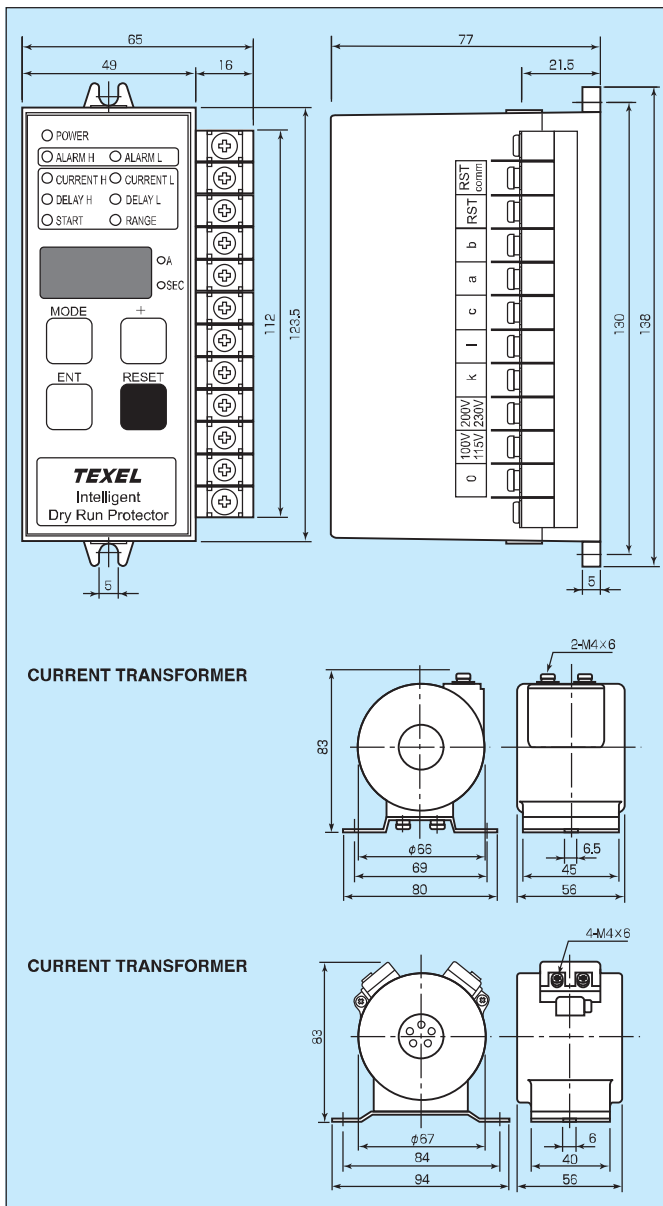

Wiring

- 1) The control power supply for the DRP is single phase, 100V~115V or 200V~230V. Connect the "b" contact of the output contact IC (the mark on the DRP terminal block is "b") to the excitation wire of the magnetic contact.
- 2) Among the wires between the magnetic contact and the motor, connect one wire to terminals "K" and "L" of the attached current transformer with a primary winding. Connect the secondary terminals, "k" and "l" of the current transformer to the DRP terminals "k" and "l".
- 3)

Fig. 2 Standard Circuit (Example)

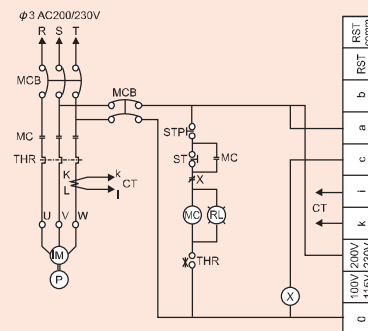
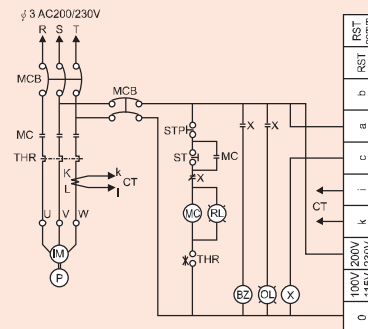

Fig. 3 Alarm Circuit (Example)



Abbreviated Codes

MCB	Main Circuit Breaker
MC	Magnetic Contact
THR	Thermal Relay
M	Motor
P	Pump
STP	Stop Button
ST	Start Button
X	Relay
BZ	Buzzer
CT	Current Transformer

Corrosion Resistance Table

Chemicals	Chemical Formula	Density (%)	Specific Gravity	Max. Use Temp. (°C)											
				Casing · Impeller				Shaft · Bearing				Gasket		O-ring	
				PFA	PVDF	ETFE	PP	Alumina Ceramic	C-PTFE	G-PTFE	Carbon	SiC	PTFE	FPM	EPDM
Acetaldehyde	CH ₃ CHO	100	0.78	bp	NR	bp	NR	bp	bp	bp	—	bp	bp	bp	—
Acetic Acid	CH ₃ COOH	10	1.01	150	60	—	100	bp	90	90	—	bp	150	NR	40
		50	1.05	150	40	80	60	bp	90	90	80	bp	150	NR	40
		80	1.06	150	NR	—	—	bp	90	90	—	bp	150	NR	NR
Acetone	CH ₃ COCH ₃	100	1.00	bp	NR	bp	60	bp	bp	bp	bp	bp	bp	NR	bp
Acetonitrile	CH ₃ CN		0.98	bp	50	bp	—	bp	bp	bp	—	bp	bp	—	NR
Adipic Acid	HOOC(CH ₂) ₄ COOH	sat.	1.36	150	90	80	80	bp	90	90	—	bp	—	80	60
Aluminium Chloride	AlCl ₃	sat.		150	90	80	80	bp	90	90	90	bp	150	90	80
Aluminium Hydroxide	Al(OH) ₃	sat.		150	90	80	100	bp	90	90	—	bp	150	80	60
Aluminium Sulfate	Al ₂ (SO ₄) ₃	sat.		150	90	100	80	bp	90	90	90	bp	150	80	60
Ammonium Carbonate	(NH ₄) ₂ CO ₃	sat.		150	90	80	100	bp	90	90	—	bp	150	90	80
Ammonium Chloride	NH ₄ Cl	sat.		150	90	80	100	bp	90	90	90	bp	150	90	80
Ammonium Fluoride	NH ₄ F	sat.		150	90	80	—	bp	90	90	90	bp	150	60	60
Ammonium Nitrate	NH ₄ NO ₃			150	90	80	60	bp	90	90	—	bp	150	90	60
Aqua Regia				150	NR	NR	NR	bp	90	90	NR	bp	150	40	NR
Aqueous Ammonia	NH ₄ OH	40		150	60	80	60	bp	90	90	—	bp	150	NR	60
Arsenic Acid	H ₃ AsO ₄ / 2H ₂ O	sat.	1.10	150	80	80	80	bp	90	90	90	bp	150	60	40
Benzene	C ₆ H ₆	100	0.89	bp	NR	bp	NR	bp	bp	bp	20	bp	bp	NR	NR
Benzyl Chloride	C ₆ H ₅ CH ₂ Cl	100		150	80	80	—	bp	90	90	—	bp	150	—	—
Boric Acid	H ₃ BO ₃	sat.		150	90	100	100	bp	90	90	90	bp	150	90	60
Bromine Water	Br ₂ / H ₂ O	sat.		80	80	80	NR	bp	90	90	80	bp	150	40	NR
Butyl Acetate	CH ₃ COO(CH ₂) ₃ CH ₃	100		bp	NR	80	NR	bp	90	90	—	bp	bp	NR	NR
Calcium Carbonate	CaCO ₃	sat.		150	90	80	—	bp	90	90	—	bp	150	90	60
Calcium Chloride	CaCl ₂	sat.		150	90	80	100	bp	90	90	90	bp	150	90	60
Calcium Phosphate	Ca ₃ (PO ₄) ₂	sat.		150	90	100	—	bp	90	90	—	bp	150	—	—
Carbon Tetrachloride	CCl ₄			150	60	65	NR	bp	90	90	—	bp	150	60	NR
Chromic Acid	Cr ₂ O ₃	40		150	80	—	NR	*bp	90	90	100	bp	150	80	—
		50		—	50	100	NR	*bp	90	90	NR	bp	150	50	—
Chloride Solution				150	90	80	NR	bp	90	90	NR	bp	150	90	NR
Chloroform	CHCl ₃	100	1.50	bp	60	NR	NR	bp	bp	bp	NR	bp	bp	NR	NR
Citric Acid		10	1.67	150	90	80	100	bp	90	90	90	bp	150	90	80
Copper Sulfate	CuSO ₄	sat.		150	90	100	—	bp	90	90	—	bp	150	90	80
Cyclohexane	C ₆ H ₁₂	100	0.78	bp	80	40	20	bp	bp	bp	40	bp	bp	40	NR
Dimethylamine	(CH ₃) ₂ NH	100	0.68	bp	NR	—	60	bp	bp	bp	bp	bp	bp	NR	NR
Ethyl Acetate	CH ₃ CO ₂ C ₂ H ₅	100		bp	NR	65	20	bp	bp	bp	—	bp	bp	NR	NR
Ethyl Alcohol	C ₂ H ₅ OH	100	0.80	bp	bp	bp	80	bp	bp	bp	bp	bp	bp	bp	bp
Ferric Chloride	FeCl ₂	sat.		150	90	80	—	bp	90	90	90	bp	150	90	80
Formaldehyde	HCOH	37	0.82	150	50	100	—	bp	90	90	—	bp	150	60	60
Formic Acid	HCOOH	90		bp	80	80	20	bp	90	90	NR	bp	bp	NR	80
Glacial Acetic Acid	CH ₃ COOH			bp	NR	80	40	bp	90	90	—	bp	bp	NR	NR
Glycolic Acid	HOCH ₂ COOH	sat.		150	NR	80	20	bp	90	90	—	bp	150	NR	NR
Hexane	CH ₃ (CH ₂) ₄ CH ₃		0.66	bp	bp	bp	20	bp	bp	bp	—	bp	bp	60	NR
Hydrobromic Acid	HBr	50	1.15	150	90	80	60	bp	90	90	90	bp	150	80	40

Chemicals	Chemical Formula	Density (%)	Specific Gravity	Max. Use Temp. (°C)											
				Casing · Impeller				Shaft · Bearing				Gasket		O-ring	
				PFA	PVDF	ETFE	PP	Alumina Ceramic	C-PTFE	G-PTFE	Carbon	SiC	PTFE	FPM	EPDM
Hydrochloric Acid	HCl	10	1.05	bp	90	bp	40	bp	90	90	—	bp	bp	90	60
		30	1.15	bp	80	bp	40	bp	90	90	—	bp	bp	80	—
		36		bp	bp	bp	40	bp	bp	bp	bp	bp	bp	80	—
Hydrofluoric Acid	HF	30	1.10	150	90	80	★60	NR	90	90	85	bp	150	60	NR
		70	1.17	150	40	80	★20	NR	90	90	—	bp	150	NR	NR
Iso-propyl Alcohol	(CH ₃)CHOH	100		bp	60	45	100	bp	bp	bp	—	bp	bp	60	60
Magnesium Chloride	MgCl ₂	sat.		150	90	80	—	bp	90	90	90	bp	150	80	80
Magnesium Hydroxide	Mg(OH) ₂	sat.		150	80	80	—	bp	90	90	90	bp	150	90	80
Methyl Alcohol	CH ₃ OH	100	0.79	bp	bp	bp	60	bp	bp	bp	NR	bp	bp	NR	60
Methylene Chloride	CH ₂ Cl ₂			bp	NR	bp	—	bp	bp	bp	—	bp	bp	NR	NR
Methylene Dibromide	CH ₂ Br ₂			bp	bp	bp	—	bp	bp	bp	—	bp	bp	20	NR
Nickel Sulfate	NiSO ₄	sat.	1.06	150	90	100	—	bp	90	90	90	bp	150	90	80
Nitrobenzene	C ₆ H ₅ NO ₂		1.21	150	NR	80	60	bp	90	90	—	bp	150	60	NR
Nitric Acid	HNO ₃	10	1.06	bp	80	—	20	bp	90	90	—	bp	bp	90	—
		50	1.32	bp	50	65	NR	bp	90	90	80	bp	bp	80	NR
		98	1.51	bp	NR	40	NR	NR	bp	bp	NR	bp	bp	NR	NR
Oleum	H ₂ SO ₄ +SO ₃			150	NR	NR	NR	bp	NR	NR	NR	bp	150	NR	NR
Phosphoric Acid	H ₃ PO ₄	50	1.33	150	90	100	60	bp	90	90	80	bp	150	90	80
		85	1.69	150	90	100	60	bp	90	90	80	bp	150	90	80
Phosphorus Oxychloride	POCl ₃			150	NR	80	20	bp	90	90	—	bp	150	NR	NR
Potassium Fluoride	KF			150	90	70	—	bp	90	90	50	bp	150	90	80
Potassium Chloride	KCl			150	90	80	100	bp	90	90	90	bp	150	90	80
Potassium Bromide	KBr		1.37	150	90	80	60	bp	90	90	90	bp	150	90	80
Potassium Hydroxide	KOH	50	1.51	150	40	80	60	bp	90	90	80	bp	150	NR	80
Sodium Carbonate	Na ₂ CO ₃	sat.		150	90	80	100	bp	90	90	—	bp	150	90	80
Sodium Chloride	NaCl			150	90	80	—	bp	90	90	—	bp	150	90	—
Sodium Hydroxide	NaOH	10	1.11	bp	※50	80	100	bp	90	90	—	bp	bp	NR	80
		50	1.53	bp	※40	100	100	bp	90	90	80	bp	150	NR	80
Sodium Hypochlorite	NaClO	5		150	90	80	NR	bp	90	90	NR	bp	150	90	NR
		15		150	90	80	NR	bp	90	90	NR	bp	150	80	NR
Sodium Thiosulfate	Na ₂ S ₂ O ₃			150	90	80	60	bp	90	90	80	bp	150	60	60
Sulfuric Acid	H ₂ SO ₄	60	1.49	bp	90	100	60	bp	90	90	100	bp	bp	80	—
		90	1.81	150	80	100	NR	bp	90	90	—	bp	150	60	NR
		98	1.83	150	※50	100	NR	bp	90	90	NR	bp	150	50	NR
Thionyl Chloride	SOCl ₂			150	NR	80	NR	bp	90	90	—	bp	150	NR	NR
Toluene	CH ₃ C ₆ H ₅		0.87	bp	NR	80	NR	bp	90	90	40	bp	bp	25	NR
Trichloroacetic Acid	CCl ₃ COOH	10		—	90	—	—	bp	90	90	—	bp	150	NR	NR
		50		100	NR	40	60	bp	90	90	—	bp	150	NR	NR
Trichloroethylene	C ₂ H ₃ Cl ₃		1.46	bp	60	80	NR	bp	bp	bp	NR	bp	bp	40	NR
Xylene	C ₆ H ₄ (CH ₃) ₂		0.88	bp	90	80	NR	bp	90	90	NR	bp	bp	NR	NR

● Symbol — : No data
 NR : Not Recommended
 bp : Boiling Point
 sat. : Saturation

Note : ①Please consult us when a liquid to be used is a mixture or contains solid particles.
 ②Please consult us when selecting the material marked with ※.
 ③This table just lists a maximum use temperature for each material itself in terms of corrosion resistance.
 ④Specific Gravity column indicates reference values.
 ⑤Use of the material marked with ★ is not recommended in the case of glass fiber reinforced PP.
 ⑥The material of the shaft is alumina or SiC.
 The material of the bearing is C-PTFE, G-PTFE, carbon, or SiC.

MEP-040 Series (Suction 40A×Discharge 40A)



Pump Specifications

- Operating Temperature 0~80℃
- Rotation Direction Clockwise (viewed from the motor)
- Flange JIS 10K FF (Please consult us about ANSI/DIN standard.)
- Finish Paint Munsell 2,5B4/8(pump body)
- Motor IEC flanged induction motor
- Accessories Foundation bolts (M10×125L×40b)

50Hz Performance Curve & Technical Data

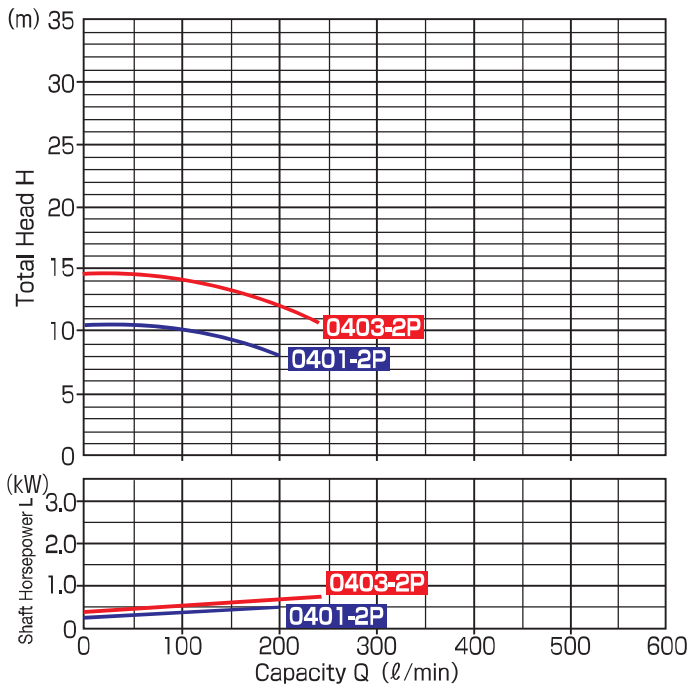

Model	Capacity (l/min)	Total Head (m)	NPSH Re (m)	Motor Output (kW)
MEP-0401-2P	100	10	1.2	0.4
MEP-0403-2P		14		0.75

Note: NPSH Re value shown in the table is that obtained from the maximum suction pipe diameter.

60Hz Performance Curve & Technical Data

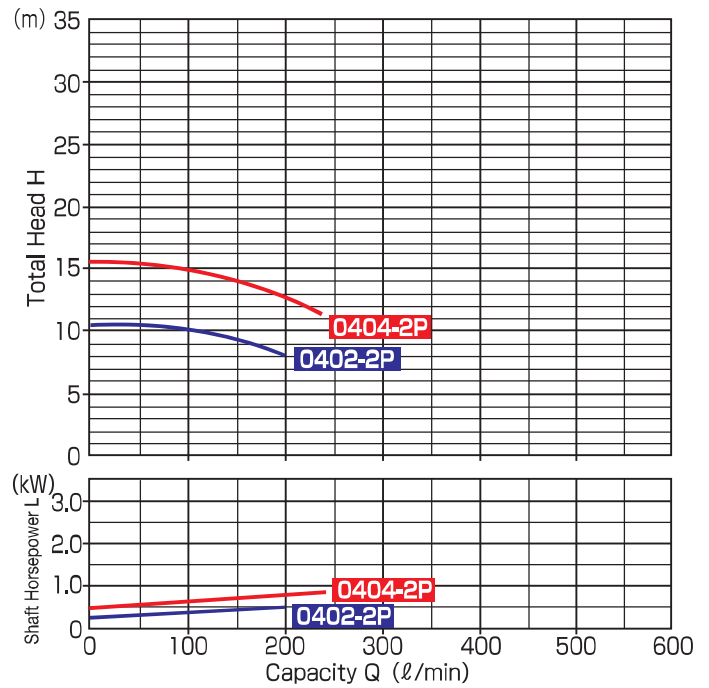

Model	Capacity (l/min)	Total Head (m)	NPSH Re (m)	Motor Output (kW)
MEP-0402-2P	100	10	1.8	0.4
MEP-0404-2P		15		0.75

Note: NPSH Re value shown in the table is that obtained from the maximum suction pipe diameter.

Pump Identification

MEP-040 1 F 00 A F F N 1

① ② ③ ④ ⑤ ⑥ ⑦ ⑧ ⑨ ⑩

- ① Model
- ② Suction Pipe Size
- ③ Model Number Please refer to Performance Curve
- ④ O-ring Material F : FPM E : EPDM Z : Other
- ⑤ Motor Output 00: 0.4kW 01: 0.75kW
- ⑥ Pump Body Material

Type	Casing	Impeller+Inner Magnet	Drain	Rear Casing
A	G-PP	G-PP+PP	PP	G-PP

- ⑦ Parts Material Combination

Type	Shaft	Front Thrust Ring	Rear Thrust Ring	Mouth Ring	Bearing
A	Alumina-ceramic			C-PTFE	
F(Standard)	Alumina-ceramic			Carbon	
Z	Other Combinations or Special Option				

- ⑧ Classification of Flange (Piping Connection Method)

F: Flange Type N: Screw-in Type

- ⑨ With or Without a Drain

N: Without a Drain D: With a Drain

- ⑩ Classification of Impeller Diameter

Seikow will determine it.

Dimensions

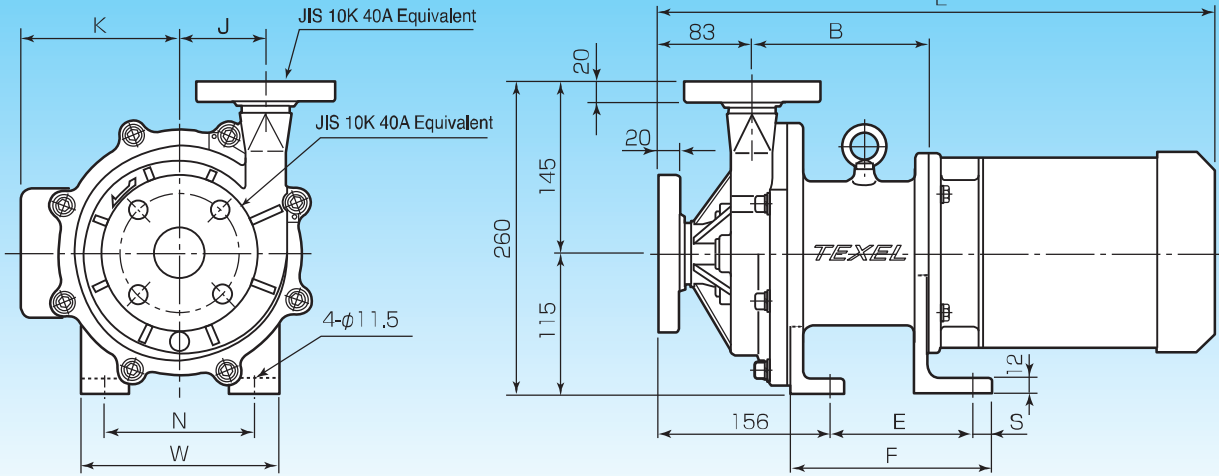

Motor Output	B	E	F	J	K	L	N	S	W	Weight (kg)
0.4kW	158	111	161	57	(150)	(480)	110	15	150	(11)
0.75kW	168	134	189	63	(150)	(500)	130	20	180	(11)

Note: ① The figures in parentheses are reference values.
 ② The weight of pump does not include the motor weight.
 ③ A 0.4-kW motor is installed on models MEP-0401 and MEP-0402.
 A 0.75-kW motor is installed on models MEP-0403 and MEP-0404.

Construction Diagram

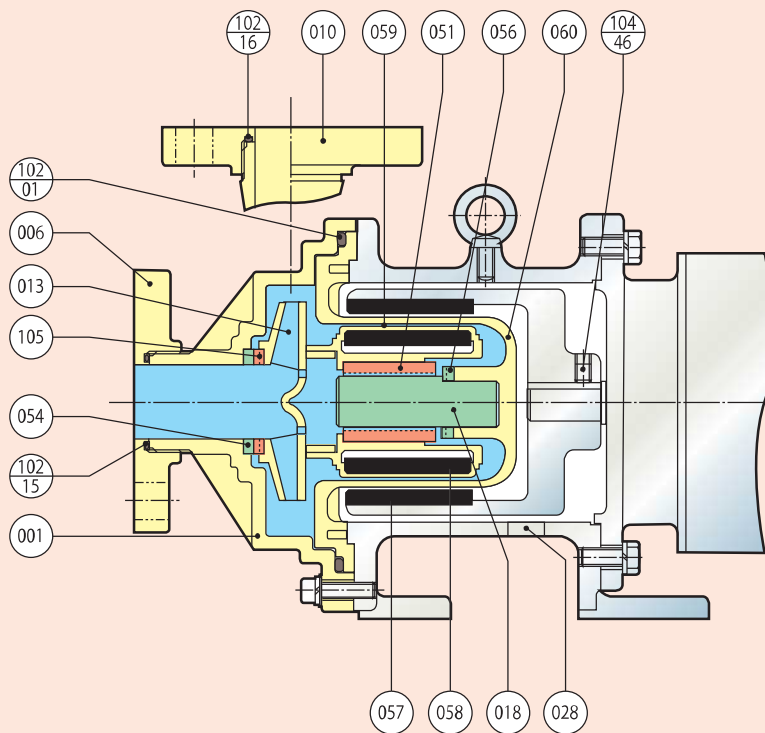

No.	Part Name	Materials
001	Casing	G-PP
006	Suction Flange	G-PP
010	Discharge Flange	G-PP
013	Impeller	G-PP
018	Shaft	Alumina-ceramic
028	Bracket	FC200
051	Bearing	Carbon/C-PTFE
054	Front Thrust Ring	Alumina-ceramic
056	Rear Thrust Ring	Alumina-ceramic
057	Outer Magnet	Ferrite
058	Inner Magnet	Ferrite
059	Magnet Lining	PP
060	Rear Casing	G-PP
102-01	O-ring(Casing)	FPM/EPDM
102-15	O-ring(Suction Flange)	FPM/EPDM
102-16	O-ring(Discharge Flange)	FPM/EPDM
104-46	Outer Magnet Set Screw	SNCM
105	Mouth Ring	Carbon/C-PTFE

Note: A 0.4-kW motor is not equipped with eyebolts.
 Inner Magnet (058) and Magnet Lining (059) are integrated and engaged with Impeller (013).

MEP-050 Series (Suction 50A × Discharge 40A)



Pump Specifications

- Operating Temperature 0~80°C
- Rotation Direction Clockwise (viewed from the motor)
- Flange JIS 10K FF (Please consult us about ANSI/DIN standard.)
- Finish Paint Munsell 2.5B4/8(pump body)
- Motor IEC flanged induction motor
- Accessories Foundation bolts (M12×160L×50b)

50Hz Performance Curve & Technical Data

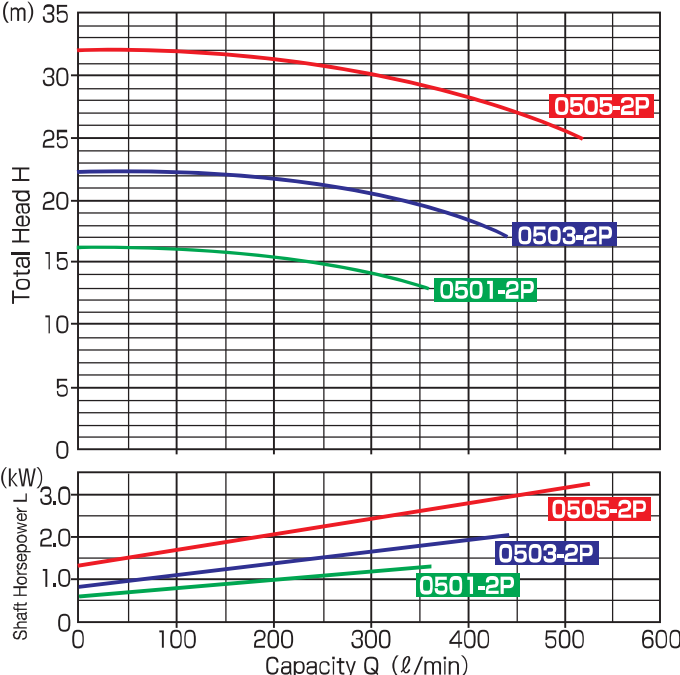

Model	Capacity (ℓ/min)	Total Head (m)	NPSH Re (m)	Motor Output (kW)
MEP-0501-2P	200	15	2.2	1.5~3.7
MEP-0503-2P	300	20	3.1	
MEP-0505-2P	400	28	4.2	

Note: NPSH Re values shown in the table are those obtained from the maximum suction pipe diameter.

60Hz Performance Curve & Technical Data

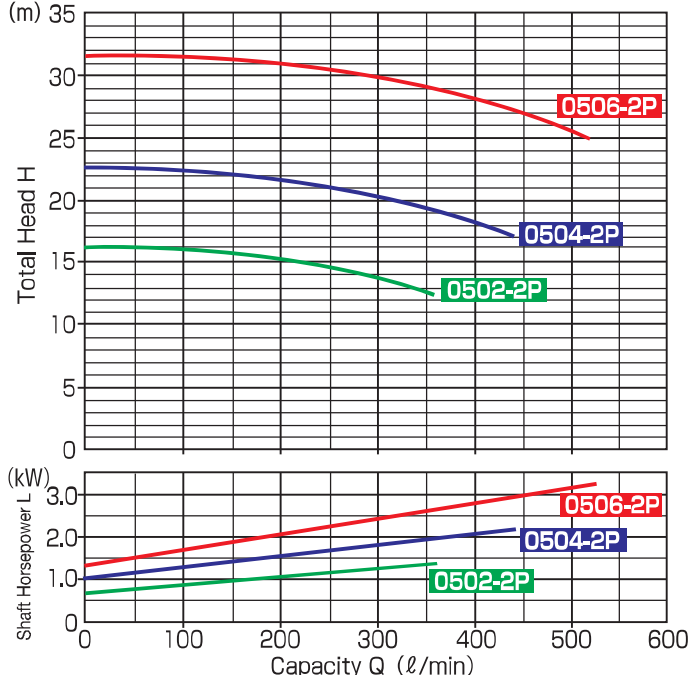

Model	Capacity (ℓ/min)	Total Head (m)	NPSH Re (m)	Motor Output (kW)
MEP-0502-2P	200	15	2.8	1.5~3.7
MEP-0504-2P	300	20	3.8	
MEP-0506-2P	400	28	4.8	

Note: NPSH Re values shown in the table are those obtained from the maximum suction pipe diameter.

Pump Identification

MEP-050 1 F 02 A F F N 1

① ② ③ ④ ⑤ ⑥ ⑦ ⑧ ⑨ ⑩

- ① Model
- ② Suction Pipe Size
- ③ Model Number Please refer to Performance Curve
- ④ O-ring Material F : FPM E : EPDM Z : Other
- ⑤ Motor Output 02 : 1.5kW 03 : 2.2kW 05 : 3.7kW
- ⑥ Pump Body Material

Type	Casing	Impeller+Inner Magnet	Drain	Rear Casing
A	G-PP	G-PP+PP	PP	G-PP

- ⑦ Parts Material Combination

Type	Shaft	Front Thrust Ring	Rear Thrust Ring	Mouth Ring	Bearing
A		Alumina-ceramic		C-PTFE	
F(Standard)		Alumina-ceramic		Carbon	
Z	Other Combinations or Special Option				

- ⑧ Classification of Flange (Piping Connection Method)
F : Flange Type N : Screw-in Type
- ⑨ With or Without a Drain
N : Without a Drain D : With a Drain
- ⑩ Classification of Impeller Diameter
Seikow will determine it.

Dimensions

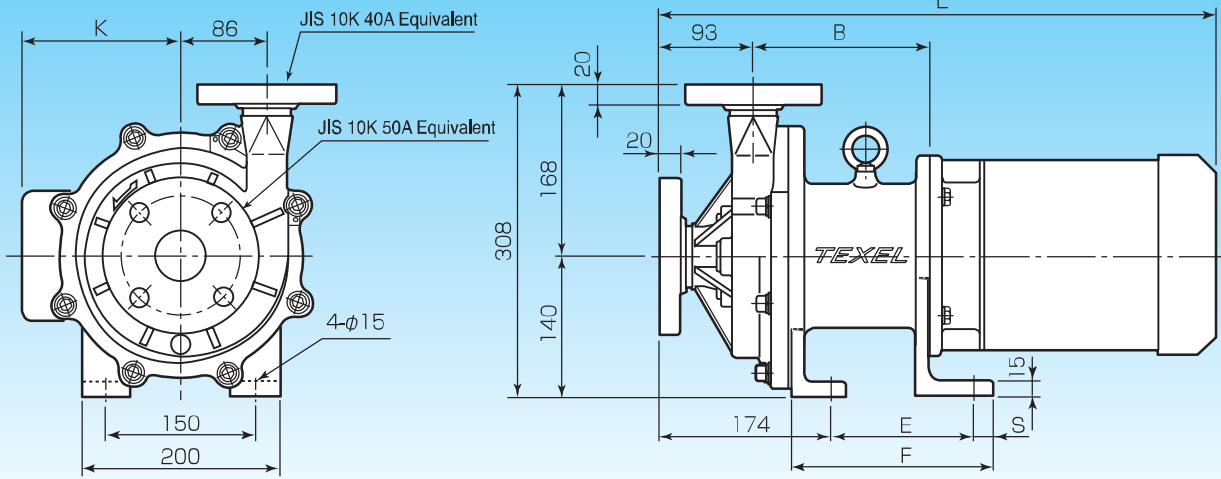

Motor Output	B	E	F	K	L	S	Weight (kg)
1.5kW	180	146	206	(160)	(570)	20	(19)
2.2kW							
3.7kW	190	187	254	(180)	(630)	27	

Note: ① The figures in parentheses are reference values.
 ② The weight of pump does not include the motor weight.
 ③ When using special motors (such as explosion-proof motors), please contact us for dimensions.

Construction Diagram

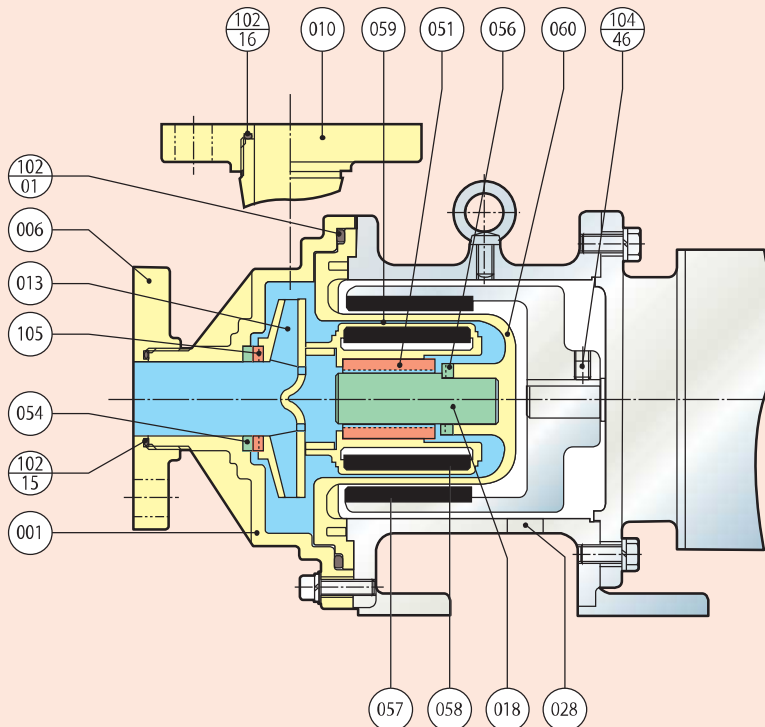

No.	Part Name	Materials
001	Casing	G-PP
006	Suction Flange	G-PP
010	Discharge Flange	G-PP
013	Impeller	G-PP
018	Shaft	Alumina-ceramic
028	Bracket	FC200
051	Bearing	Carbon/C-PTFE
054	Front Thrust Ring	Alumina-ceramic
056	Rear Thrust Ring	Alumina-ceramic
057	Outer Magnet	Ferrite / Rare Earth
058	Inner Magnet	Ferrite / Rare Earth
059	Magnet Lining	PP
060	Rear Casing	G-PP
102-01	O-ring (Casing)	FPM/EPDM
102-15	O-ring (Suction Flange)	FPM/EPDM
102-16	O-ring (Discharge Flange)	FPM/EPDM
104-46	Outer Magnet Set Screw	SNCM
105	Mouth Ring	Carbon/C-PTFE

Note: Materials of Inner and Outer Magnets
 For 1.5-kW motor output, the materials are ferrites.
 For 2.2-kW and 3.7-kW motor output, the materials are rare earth elements.
 Inner Magnet (058) and Magnet Lining (059) are integrated and engaged with Impeller (013).

MEP-080 Series (Suction 80A × Discharge 65A)

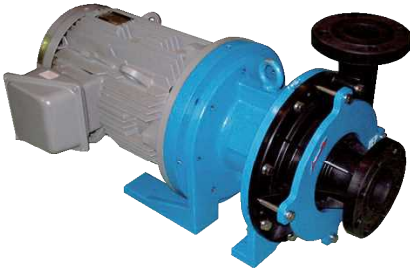

Pump Specifications

- Operating Temperature 0~80°C
- Rotation Direction Clockwise (viewed from the motor)
- Flange JIS 10KRF (Please consult us about ANSI/DIN standard.)
- Finish Paint Munsell 2.5B4/8(pump body)
- Motor IEC flanged induction motor
- Accessories Foundation bolts (M12×160L×50b)

50Hz Performance Curve & Technical Data

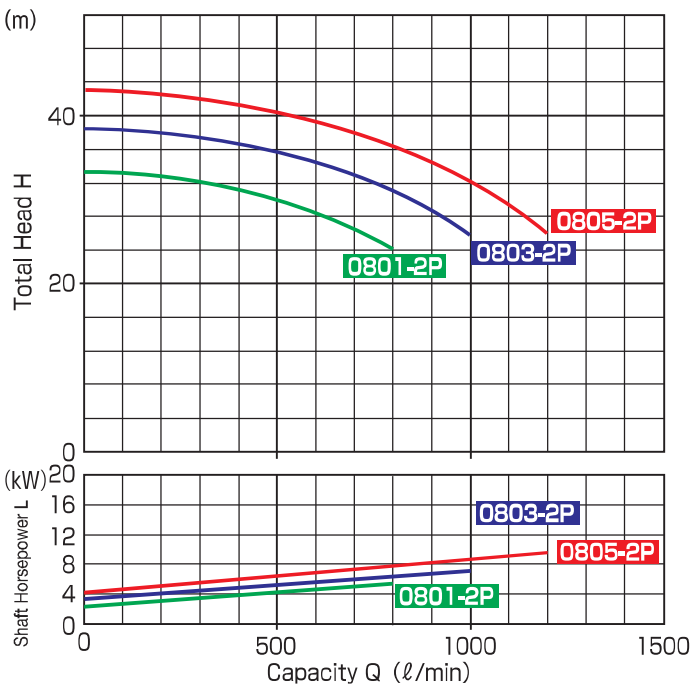

Model	Capacity (l/min)	Total Head (m)	NPSH Re (m)	Motor Output (kW)
MEP-0801	600	28	3.0	5.5
MEP-0803	800	30	4.0	7.5
MEP-0805	1040		5.4	11

Note: NPSH Re values shown in the table are those obtained from the maximum suction pipe diameter.

60Hz Performance Curve & Technical Data

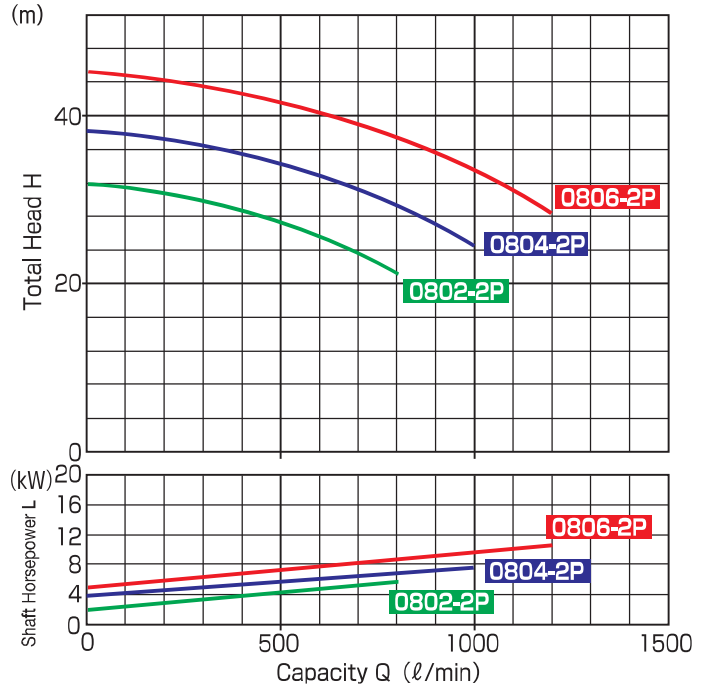

Model	Capacity (l/min)	Total Head (m)	NPSH Re (m)	Motor Output (kW)
MEP-0802	600	25	3.2	5.5
MEP-0804	800	29	4.3	7.5
MEP-0806	1030	32	5.9	11

Note: NPSH Re values shown in the table are those obtained from the maximum suction pipe diameter.

Pump Identification

MEP-080 1 F 07 A A F N 1

① ② ③ ④ ⑤ ⑥ ⑦ ⑧ ⑨ ⑩

- ① Model
- ② Suction Pipe Size
- ③ Model Number Please refer to Performance Curve
- ④ O-ring Material F : FPM E : EPDM Z : Other (FEPM)
- ⑤ Motor Output 07 : 5.5kW 10 : 7.5kW 15 : 11kW
- ⑥ Pump Body Material

Type	Casing	Impeller+Inner Magnet	Drain	Rear Casing
A	G-PP	G-PP+PP	PP	G-PP

⑦ Parts Material Combination

Type	Shaft	Front Thrust Ring	Rear Thrust Ring	Mouth Ring	Bearing
A		Alumina-ceramic		C-PTFE (Standard)	
B		(SiC)			
C		(SiC)		Carbon	
E		(SiC)		C-PTFE	
F		Alumina-ceramic		Carbon	
Z	Other Combinations or Special Option				

⑧ Classification of Flange (Piping Connection Method)

F: Flange Type N: Screw-in Type

⑨ With or Without a Drain

N: Without a Drain D: With a Drain

⑩ Classification of Impeller Diameter

Seikow will determine it.

Dimensions

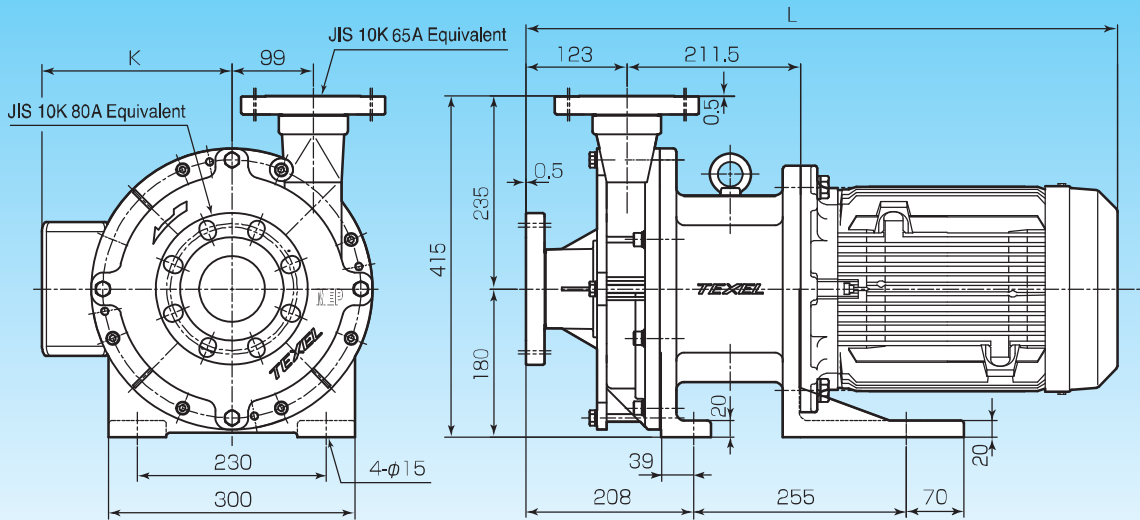

Motor Output	K	L	Weight (kg)
5.5kW	(231)	(720)	51
7.5kW			
11kW	(255)	(849.5)	

Note: ① The weight of pump does not include the motor weight.
 ② The figures in parentheses are reference values.

Construction Diagram

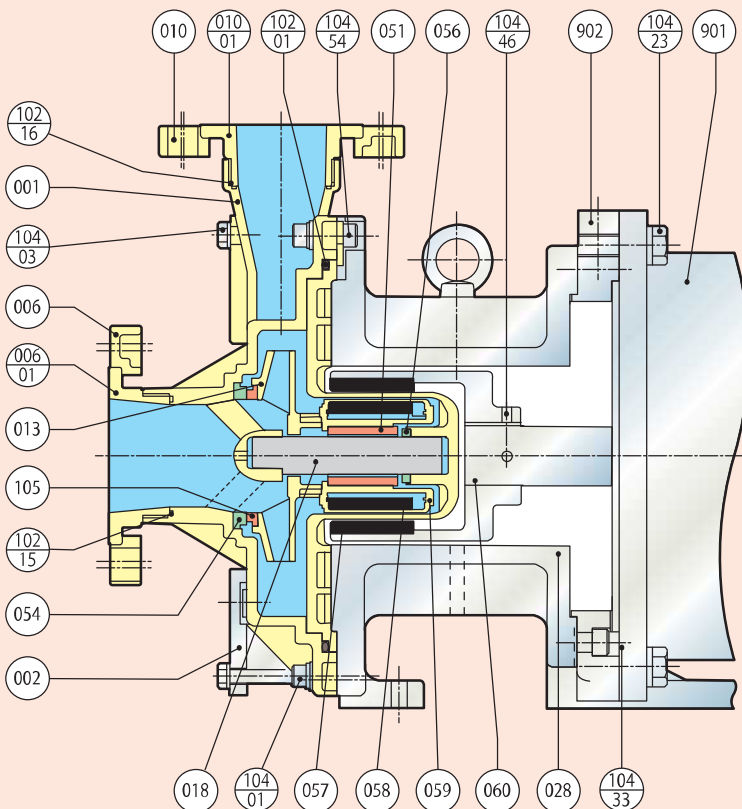

No.	Part Name	Materials
001	Casing	G-PP
002	Casing Cover	FC200
006	Suction Flange	G-PP
006-01	Suction Flange Adapter	G-PP
010	Discharge Flange	G-PP
010-01	Discharge Flange Adapter	G-PP
013	Impeller	G-PP
018	Shaft	Alumina-ceramic
028	Bracket	FC200
051	Bearing	Carbon/C-PTFE
054	Front Thrust Ring	Alumina-ceramic
056	Rear Thrust Ring	Alumina-ceramic
057	Outer Magnet	Rare Earth
058	Inner Magnet	Rare Earth
059	Magnet Lining	PP
060	Rear Casing	G-PP
102-01	O-ring(Casing)	FPM/EPDM
102-15	O-ring(Suction Flange)	FPM/EPDM
102-16	O-ring(Discharge Flange)	FPM/EPDM
104-01	Casing Bolt	SUS304
104-03	Casing Cover Bolt	SUS304
104-23	Motor Bolt	SUS304
104-33	Motor Liner Bolt	SUS304
104-46	Outer Magnet Set Screw	SNCM
104-54	Rear Casing Bolt	SUS304
105	Mouth Ring	Carbon/C-PTFE
901	Motor	
902	Motor Liner	SS400

Note: Inner Magnet (058) and Magnet Lining (059) are integrated and engaged with Impeller (013).

MER-051 Series (Suction 50A × Discharge 40A)

MER Series



Pump Specifications

- Operating Temperature 0~90°C
- Rotation Direction Clockwise (viewed from the motor)
- Flange JIS 10K RF (Please consult us about ANSI/DIN standard.)
- Finish Paint Munsell 2.5B4/8(pump body)
- Motor TEXEL flanged induction motor / IEC flanged induction motor
- Accessories Foundation bolts (M12×160L×50b)

50Hz Performance Curve & Technical Data

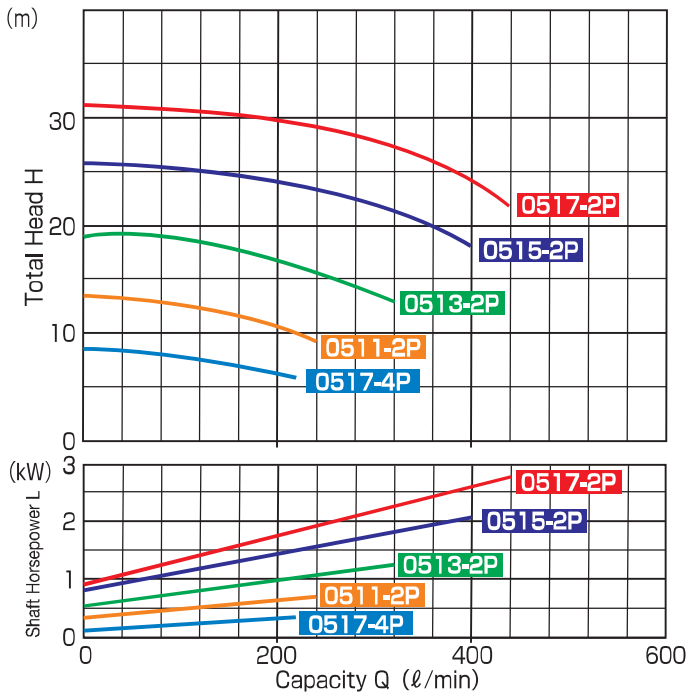

Model	Capacity (ℓ/min)	Total Head (m)	NPSH Re (m)	Motor Output (kW)
MER-0511-2P	200	10	2.4	0.75~3.7
MER-0513-2P	250	15	2.8	
MER-0515-2P	350	20	5.5	
MER-0517-2P	350	25	5.5	0.4~0.75
MER-0517-4P	200	6	2.4	

Note: ① Motor output of 0.4 kW (4-pole) is only applicable when a TEXEL flanged induction motor is used.
 ② Motor output of 3.7 kW is only applicable when an IEC flanged induction motor is used.
 ③ NPSH Re values shown in the table are those obtained from the maximum suction pipe diameter.

60Hz Performance Curve & Technical Data

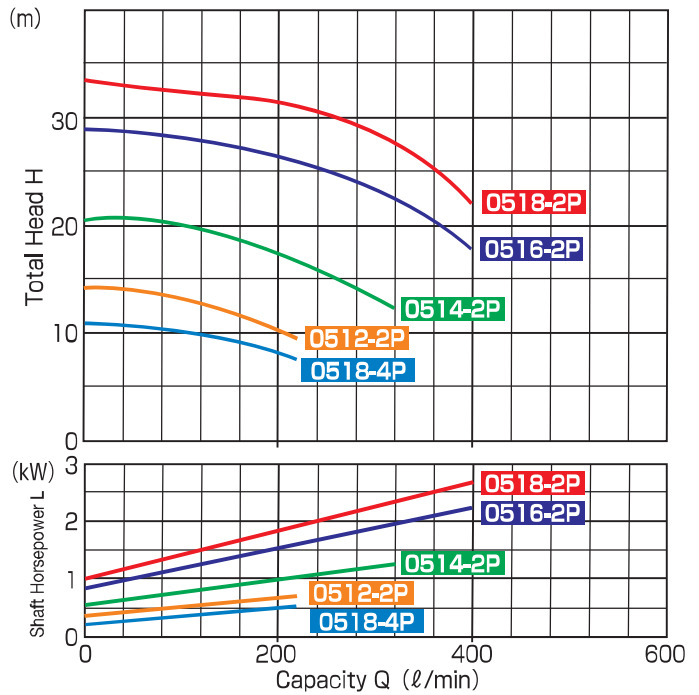

Model	Capacity (ℓ/min)	Total Head (m)	NPSH Re (m)	Motor Output (kW)
MER-0512-2P	200	10	2.8	0.75~3.7
MER-0514-2P	250	15	3.6	
MER-0516-2P	350	20	6.6	
MER-0518-2P	350	25	6.6	0.4~0.75
MER-0518-4P	200	8	2.7	

Note: ① Motor output of 0.4 kW (4-pole) is only applicable when a TEXEL flanged induction motor is used.
 ② Motor output of 3.7 kW is only applicable when an IEC flanged induction motor is used.
 ③ NPSH Re values shown in the table are those obtained from the maximum suction pipe diameter.

Pump Identification

MER-051 1 F 01 P S A 4
 ① ② ③ ④ ⑤ ⑥ ⑦ ⑧ ⑨

- ① Model
- ② Suction Pipe Size
- ③ Model Number Please refer to Performance Curve
- ④ O-ring Material F : FPM E : EPDM Z : Other
- ⑤ Motor Output 00 : 0.4kW 01 : 0.75kW
02 : 1.5kW 03 : 2.2kW 05 : 3.7kW
- ⑥ Pump Body Material

Type	Casing	Impeller+Inner Magnet	Drain	Rear Casing
P		PVDF		C-PVDF
H		ETFE		C-PVDF
E		ETFE		C-ETFE
Z	Other Combinations or Special Option			

⑦ Motor Type

S : TEFC/outdoor TEXEL motor A : Explosion-proof increased safety (eG3) TEXEL motor
 T : IEC standard explosion-proof (d2G4) motor C : Other

⑧ Parts Material Combination

Type	Shaft	Front Thrust Ring	Rear Thrust Ring	Front Bearing	Rear Bearing
A(Standard)	Alumina-ceramic			C-PTFE	
B			SiC		
E	SiC			C-PTFE	
F	Alumina-ceramic			Carbon	
G	Alumina-ceramic			G-PTFE	
Z	Other Combinations or Special Option				

⑨ Number of Poles

"4" is shown only when a 4-pole motor is installed.

Dimensions

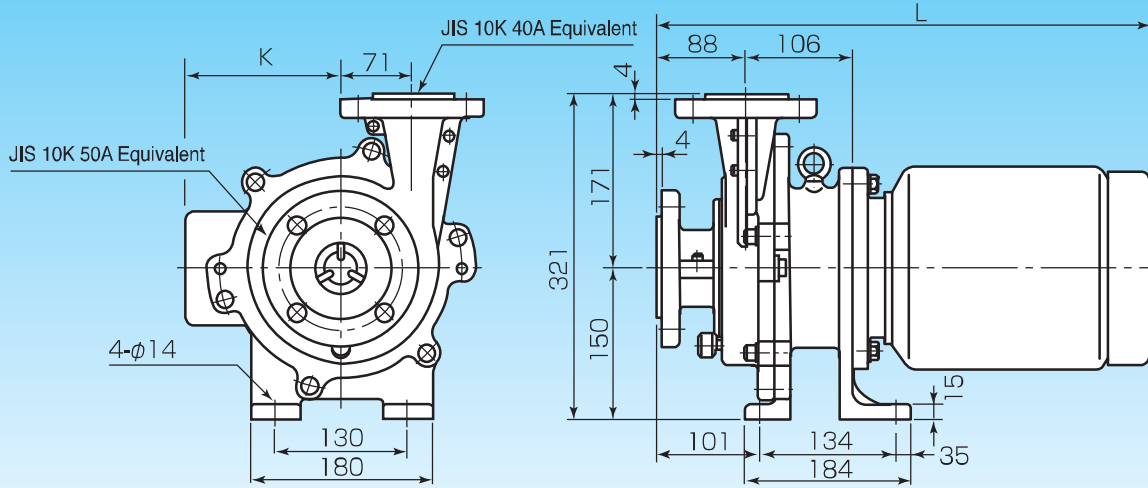

Motor Output (kW)	TEFC		eG3		Weight (kg)
	K	L	K	L	
0.4	147	419	150	428	(26)
0.75	157	451	159	464	
1.5	153	479	168	477	
2.2			176	545	
3.7	169	549	169	549	

Note:
 ① The weight of pump does not include the motor weight.
 ② The lengths shown to the left are applicable when a TEXEL flanged induction motor is used.
 ③ The figures in parentheses are reference values.

Construction Diagram

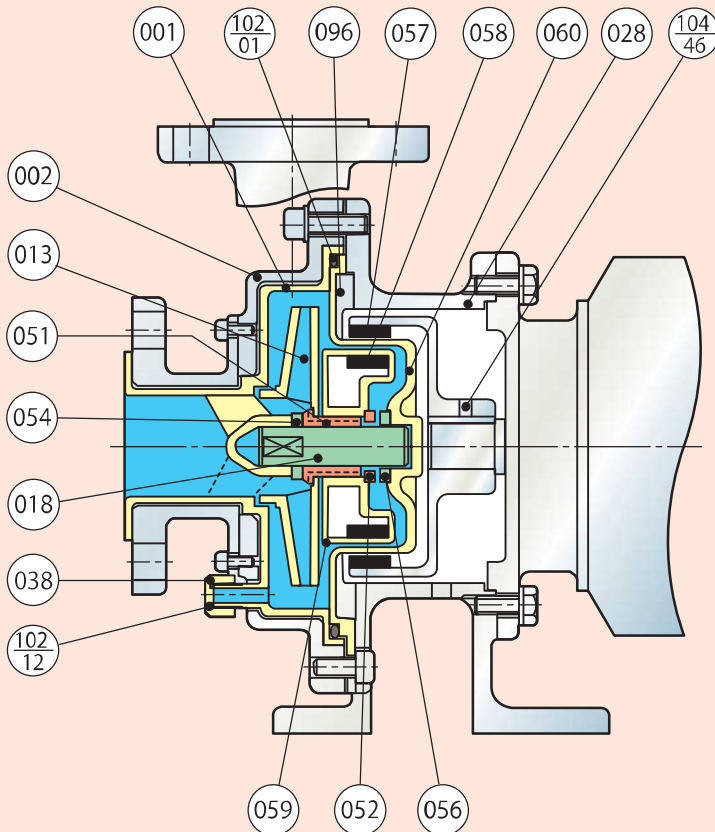

No.	Part Name	Materials
001	Casing	PVDF / ETFE
002	Casing Cover	FC200
013	Impeller	PVDF / ETFE
018	Shaft	Alumina-ceramic / SiC
028	Bracket	FC200
038	Drain Plug	PVDF / ETFE
051	Front Bearing	C-PTFE / SiC / Carbon / G-PTFE
052	Rear Bearing	C-PTFE / SiC / Carbon / G-PTFE
054	Front Thrust Ring	Alumina-ceramic / SiC
056	Rear Thrust Ring	Alumina-ceramic / SiC
057	Outer Magnet	Rare Earth
058	Inner Magnet	Rare Earth
059	Magnet Lining	PVDF / ETFE
060	Rear Casing	C-PVDF / C-ETFE
096	Bracket Ring	SS400
102-01	O-ring(Casing)	FPM / EPDM
102-12	O-ring(Drain Plug)	FPM / EPDM
104-46	Outer Magnet Set Screw	SNCM

Note: Inner Magnet (058), Magnet Lining (059), and Impeller (013) are integrated.

MEH-040 Series (Suction 40A × Discharge 20A)



Pump Specifications

- Operating Temperature 0~90°C
- Rotation Direction Clockwise (viewed from the motor)
- Flange JIS 10K RF (Please consult us about ANSI/DIN standard.)
- Finish Paint Munsell 2.5B4/8 (pump body)
- Motor TEXEL flanged induction motor / IEC flanged induction motor
- Accessories Foundation bolts (M12×160L×50b)

50Hz Performance Curve & Technical Data

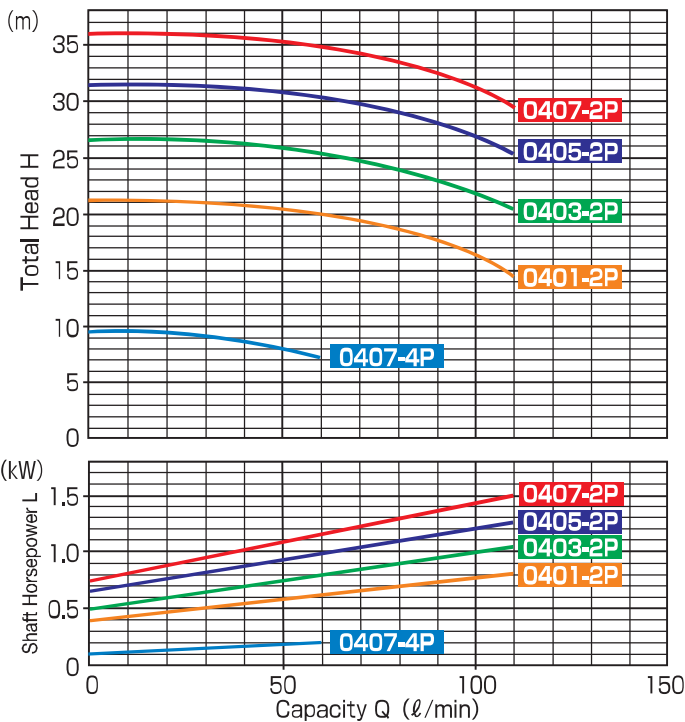

Model	Capacity (ℓ/min)	Total Head (m)	NPSH Re (m)	Motor Output (kW)
MEH-0401-2P	50	20	2.2	0.75~3.7
MEH-0403-2P		25		
MEH-0405-2P		30		
MEH-0407-2P		35		
MEH-0407-4P	60	7	1.8	0.4~0.75

Note: ① Motor output of 0.4 kW (4-pole) is only applicable when a TEXEL flanged induction motor is used.
 ② Motor output of 3.7 kW is only applicable when an IEC flanged induction motor is used.
 ③ NPSH Re values shown in the table are those obtained from the maximum suction pipe diameter.

60Hz Performance Curve & Technical Data

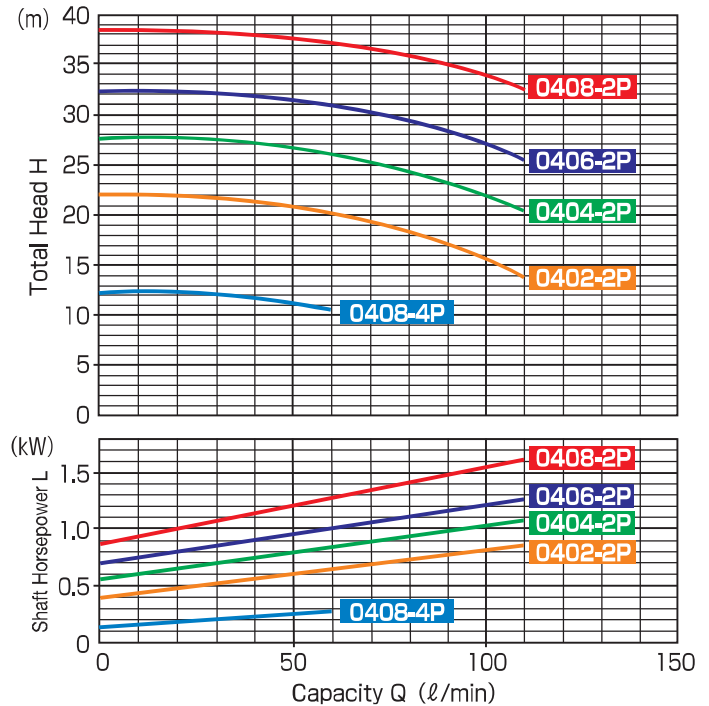

Model	Capacity (ℓ/min)	Total Head (m)	NPSH Re (m)	Motor Output (kW)
MEH-0402-2P	50	20	2.6	0.75~3.7
MEH-0404-2P		25		
MEH-0406-2P		30		
MEH-0408-2P		35		
MEH-0408-4P	60	10	2.0	0.4~0.75

Note: ① Motor output of 0.4 kW (4-pole) is only applicable when a TEXEL flanged induction motor is used.
 ② Motor output of 3.7 kW is only applicable when an IEC flanged induction motor is used.
 ③ NPSH Re values shown in the table are those obtained from the maximum suction pipe diameter.

Pump Identification

MEH-040 1 F 01 P S A 4
 ① ② ③ ④ ⑤ ⑥ ⑦ ⑧ ⑨

- ① Model
- ② Suction Pipe Size
- ③ Model Number Please refer to Performance Curve
- ④ O-ring Material F : FPM E : EPDM Z : Other
- ⑤ Motor Output 00 : 0.4kW 01 : 0.75kW
02 : 1.5kW 03 : 2.2kW 05 : 3.7kW

⑥ Pump Body Material

Type	Casing	Impeller+Inner Magnet	Drain	Rear Casing
P		PVDF		C-PVDF
H	PVDF	ETFE	PVDF	C-PVDF
Z	Other Combinations or Special Option			

⑦ Motor Type

- S : TEFC/outdoor TEXEL motor A : Explosion-proof increased safety (eG3) TEXEL motor
- T : IEC standard explosion-proof (d2G4) motor C : Other

⑧ Parts Material Combination

Type	Shaft	Front Thrust Ring	Rear Thrust Ring	Mouth Ring	Bearing
A(Standard)	Alumina-ceramic			C-PTFE	
B	SiC				
E	SiC			C-PTFE	
F	Alumina-ceramic			Carbon	
G	Alumina-ceramic			G-PTFE	
Z	Other Combinations or Special Option				

⑨ Number of Poles

"4" is shown only when a 4-pole motor is installed.

Dimensions

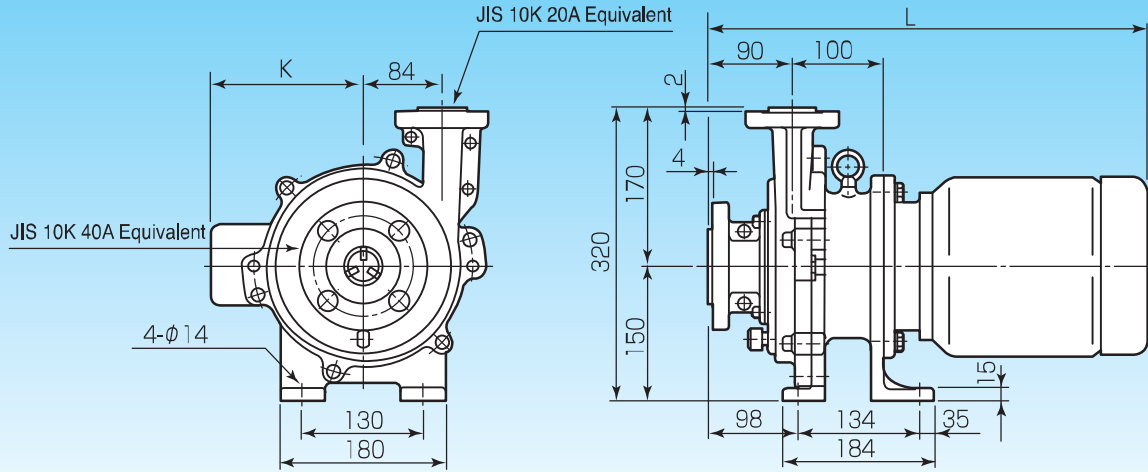

Motor Output (kW)	TEFC		eG3		Weight (kg)
	K	L	K	L	
0.4	147	415	150	424	(25)
0.75	157	447	159	460	
1.5	153	475	168	473	
2.2			176	541	

Note:

- ① The weight of pump does not include the motor weight.
- ② The dimensions shown above are applicable when a TEXEL flanged induction motor is used.
- ③ The figures in parentheses are reference values.
- ④ Please consult us when you use 3.7kW IEC flanged motor.

Construction Diagram

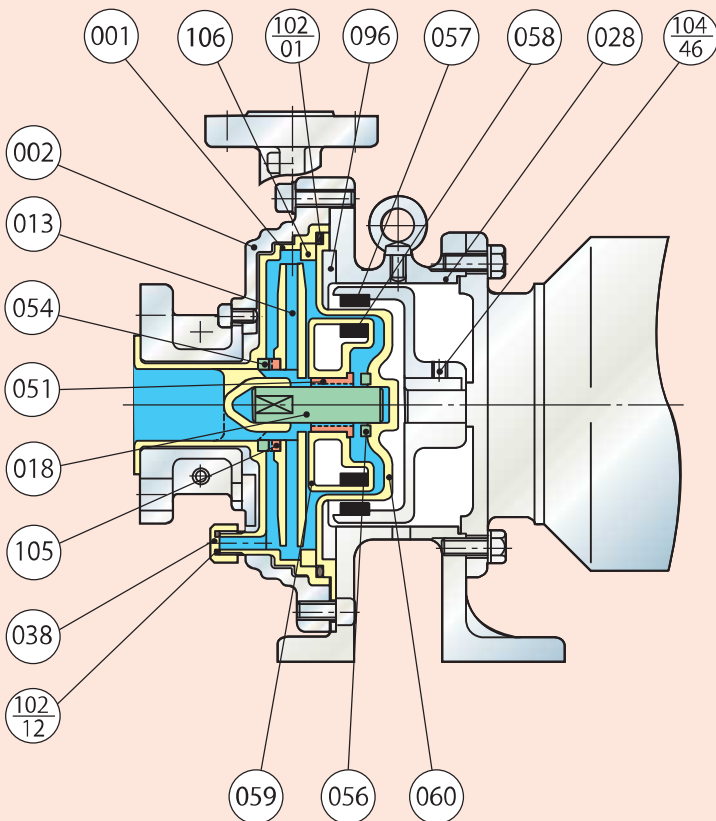

No.	Part Name	Materials
001	Casing	PVDF
002	Casing Cover	FC200
013	Impeller	PVDF/ETFE
018	Shaft	Alumina-ceramic / SiC
028	Bracket	FC200
038	Drain Plug	PVDF
051	Bearing	C-PTFE / SiC / Carbon / G-PTFE
054	Front Thrust Ring	Alumina-ceramic / SiC
056	Rear Thrust Ring	Alumina-ceramic / SiC
057	Outer Magnet	Rare Earth
058	Inner Magnet	Rare Earth
059	Magnet Lining	PVDF/ETFE
060	Rear Casing	C-PVDF
096	Bracket Ring	SS400
102-01	O-ring(Casing)	FPM/EPDM
102-12	O-ring(Drain Plug)	FPM/EPDM
104-46	Outer Magnet Set Screw	SNCM
105	Mouth Ring	C-PTFE / SiC / Carbon / G-PTFE
106	Casing Ring	PVDF

Note: Impeller has a linear channel form.
Inner Magnet (058), Magnet Lining (059), and Impeller (013) are integrated.

MET-040 Series (Suction 40A × Discharge 25A)



Pump Specifications

- Operating Temperature -20~120°C
(Please consult us about 0°C below and 100°C higher when used)
- Rotation Direction Clockwise (viewed from the motor)
- Flange JIS 10K RF (Please consult us about ANSI/DIN standard.)
- Finish Paint Munsell 2.5B4/8(pump body)
- Motor IEC flanged induction motor
- Accessories Base & Foundation bolts (M12×160L×50b)

50Hz Performance Curve & Technical Data

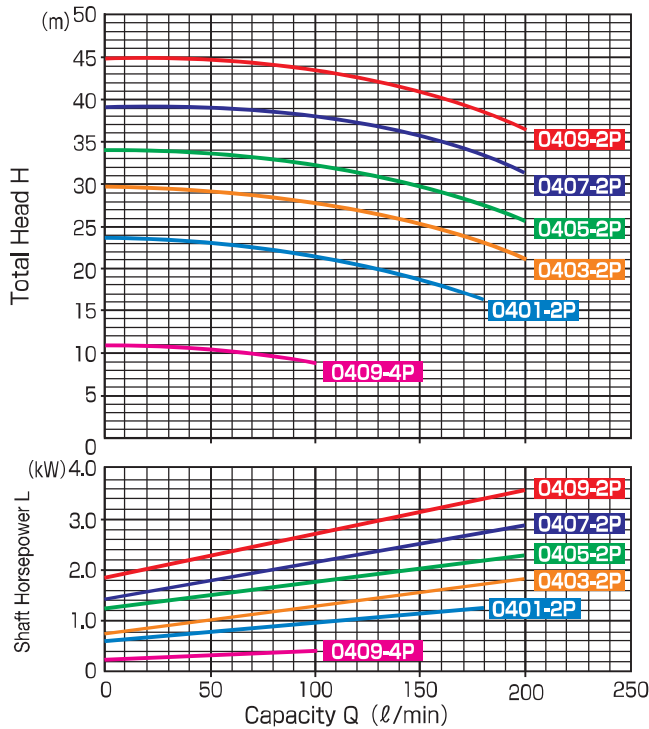

Model	Capacity (l/min)	Total Head (m)	NPSH Re (m)	Motor Output (kW)
MET-0401-2P	100	20	2.5	0.75~5.5
MET-0403-2P		25		
MET-0405-2P		30		
MET-0407-2P		35		
MET-0409-2P		40		
MET-0409-4P	50	10	1.3	0.4~2.2

Note: NPSH Re values shown in the table are those obtained from the maximum suction pipe diameter.

60Hz Performance Curve & Technical Data

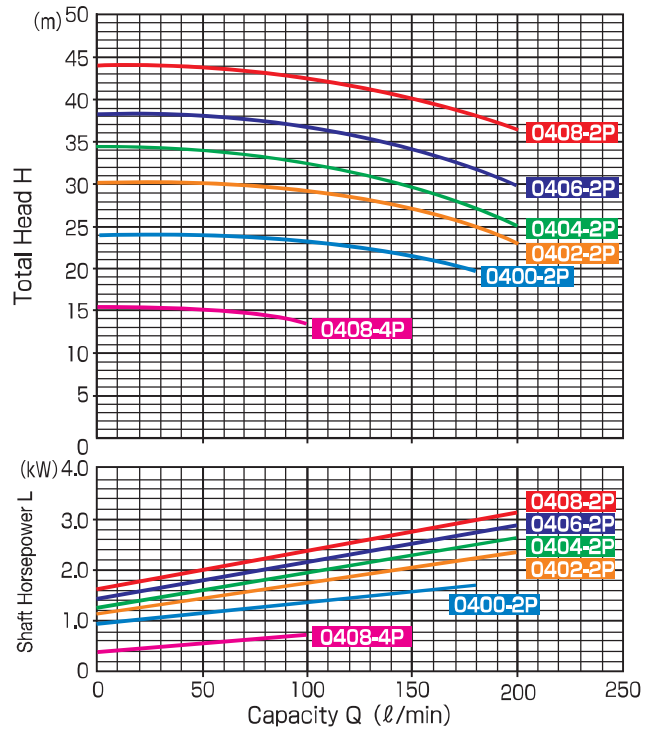

Model	Capacity (l/min)	Total Head (m)	NPSH Re (m)	Motor Output (kW)
MET-0400-2P	100	20	3.0	0.75~5.5
MET-0402-2P		25		
MET-0404-2P		30		
MET-0406-2P		35		
MET-0408-2P	50	40	1.5	0.4~2.2
MET-0408-4P		15		

Note: NPSH Re values shown in the table are those obtained from the maximum suction pipe diameter.

Pump Identification

MET-040 1 P 01 F A 4
 ① ② ③ ④ ⑤ ⑥ ⑦ ⑧

- ① Model
- ② Suction Pipe Size
- ③ Model Number Please refer to Performance Curve
- ④ Gasket Material P : PTFE (Jacketed)
Z : Other
- ⑤ Motor Output 00 : 0.4kW 01 : 0.75kW 02 : 1.5kW
03 : 2.2kW 05 : 3.7kW 07 : 5.5kW
- ⑥ Pump Body Material

Type	Casing	Impeller+Inner Magnet	Rear Casing
F		PFA	PFA+Eng.Plastic
Z	Other Combinations or Special Option		

- ⑦ Parts Material Combination

Type	Shaft	Front Thrust Ring	Rear Thrust Ring	Mouth Ring	Bearing
A(Standard)		Alumina-ceramic			C-PTFE
B		SiC			
E		SiC			C-PTFE
F		Alumina-ceramic			Carbon
G		Alumina-ceramic			G-PTFE
Z	Other Combinations or Special Option				

⑧ Number of Poles "4" is shown only when a 4-pole motor is installed.

MET Series

Dimensions

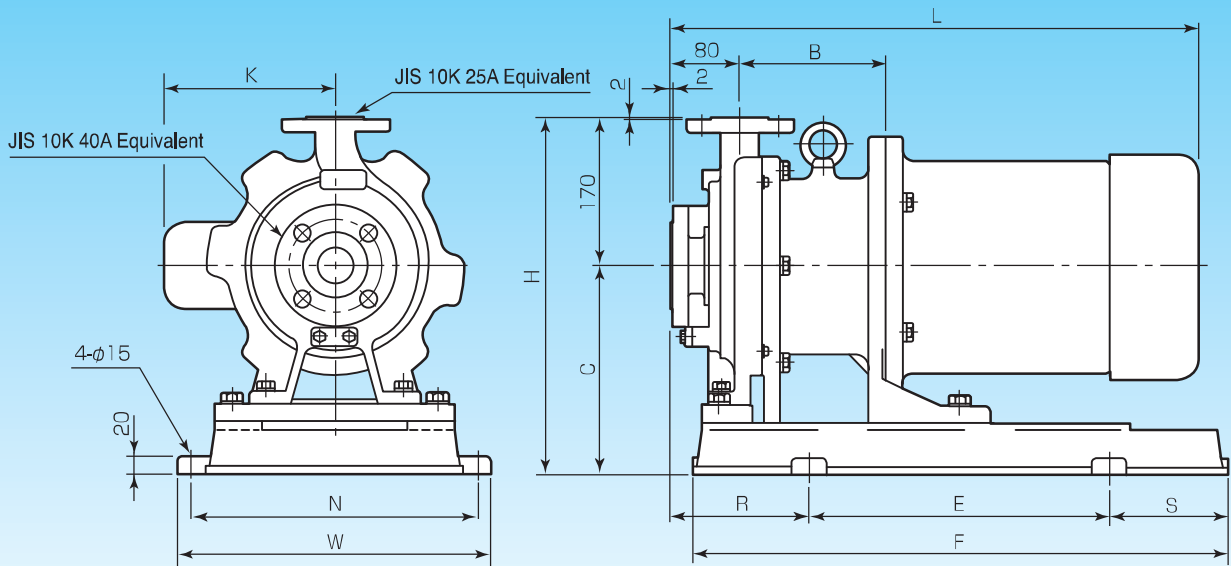

Motor Output (kW)	B	C	H	R	S	E	F	K	L	N	W	Weight (kg)
0.4	126	210	380	144	110	300	520	(200)	(665)	290	320	(69)
0.75	129											
1.5	139											
2.2	149	240	410	161.5	135	350	620		335	375		
3.7												
5.5	169											

- Note: ① The weight of pump does not include the motor weight.
 ② The dimensions shown above are applicable when a totally-enclosed fan-cooled 2-pole motor is used.
 When using special motors (such as explosion-proof motors), please contact us.
 ③ The figures in parentheses are reference values.

Construction Diagram

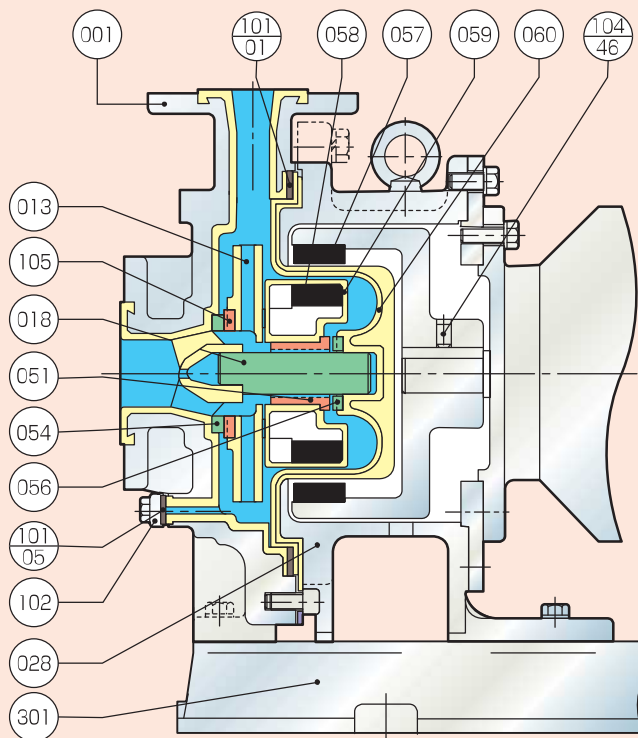

No.	Part Name	Materials
001	Casing	FCD450+PFA
013	Impeller	PFA
018	Shaft	Alumina-ceramic / SiC
028	Bracket	FC200
051	Bearing	C-PTFE / SiC / Carbon / G-PTFE
054	Front Thrust Ring	Alumina-ceramic / SiC
056	Rear Thrust Ring	Alumina-ceramic / SiC
057	Outer Magnet	Rare Earth
058	Inner Magnet	Rare Earth
059	Magnet Lining	PFA
060	Rear Casing	PFA (Wetted Parts)
101-01	Casing Gasket	PTFE (Jacketed)
101-05	Drain Gasket	PTFE (Jacketed)
102	Drain Flange	FC200
104-46	Outer Magnet Set Screw	SNCM
105	Mouth Ring	C-PTFE / SiC / Carbon / G-PTFE
301	Base	FC200

Note: Impeller has a linear channel form.
 Inner Magnet (058), Magnet Lining (059), and Impeller (013) are integrated.

MET-050 Series (Suction 50A × Discharge 40A)



Pump Specifications

- Operating Temperature -20~120°C (Please consult us about 0°C below and 100°C higher when used)
PVDF · ETFE : 0~90°C
- Rotation Direction Clockwise (viewed from the motor)
- Flange JIS 10K RF (M16 Tapped hole) (Please consult us about ANSI/DIN standard.)
- Finish Paint Munsell 2.5B4/8(pump body)
- Motor IEC flanged induction motor
- Accessories Base & Foundation bolts (M12×160L×50b)

50Hz Performance Curve & Technical Data

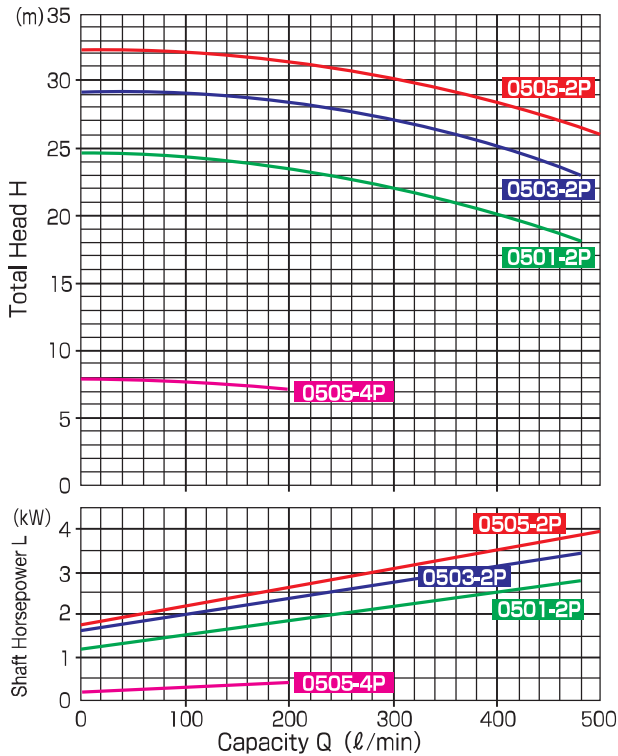

60Hz Performance Curve & Technical Data

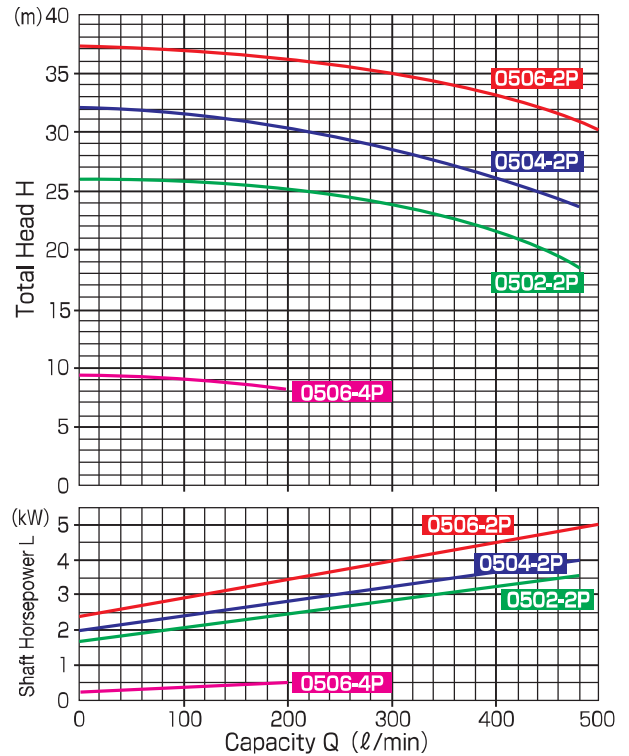

Model	Capacity (ℓ/min)	Total Head (m)	NPSH Re (m)	Motor Output (kW)
MET-0501-2P	400	20	2.5	1.5~5.5
MET-0503-2P		25		
MET-0505-2P		29		
MET-0505-4P	200	6	1.8	1.5~2.2

Note: NPSH Re values shown in the table are those obtained from the maximum suction pipe diameter.

Model	Capacity (ℓ/min)	Total Head (m)	NPSH Re (m)	Motor Output (kW)
MET-0502-2P	400	20	2.5	1.5~5.5
MET-0504-2P		25		
MET-0506-2P		30		
MET-0506-4P	200	10	1.8	1.5~2.2

Note: NPSH Re values shown in the table are those obtained from the maximum suction pipe diameter.

Pump Identification

MET - 050 1 P 01 P A 4
 ① ② ③ ④ ⑤ ⑥ ⑦ ⑧

- ① Model
- ② Suction Pipe Size
- ③ Model Number Please refer to Performance Curve
- ④ Gasket Material P : PTFE (Jacketed)
Z : Other
- ⑤ Motor Output 01 : 0.75kW 02 : 1.5kW 03 : 2.2kW
05 : 3.7kW 07 : 5.5kW
- ⑥ Pump Body Material

Type	Casing	Impeller+Inner Magnet	Rear Casing
P	PFA	PVDF	PFA+Eng.Plastic
H	PFA	ETFE	
F	PFA		
Z	Other Combinations or Special Option		

- ⑦ Parts Material Combination

Type	Shaft	Rear Thrust Ring	Front Bearing	Rear Bearing
A(Standard)	Alumina-ceramic		C-PTFE	
B	SIC			
E	SIC		C-PTFE	
F	Alumina-ceramic		Carbon	
G	Alumina-ceramic		G-PTFE	
Z	Other Combinations or Special Option			

- ⑧ Number of Poles "4" is shown only when a 4-pole motor is installed.

Dimensions

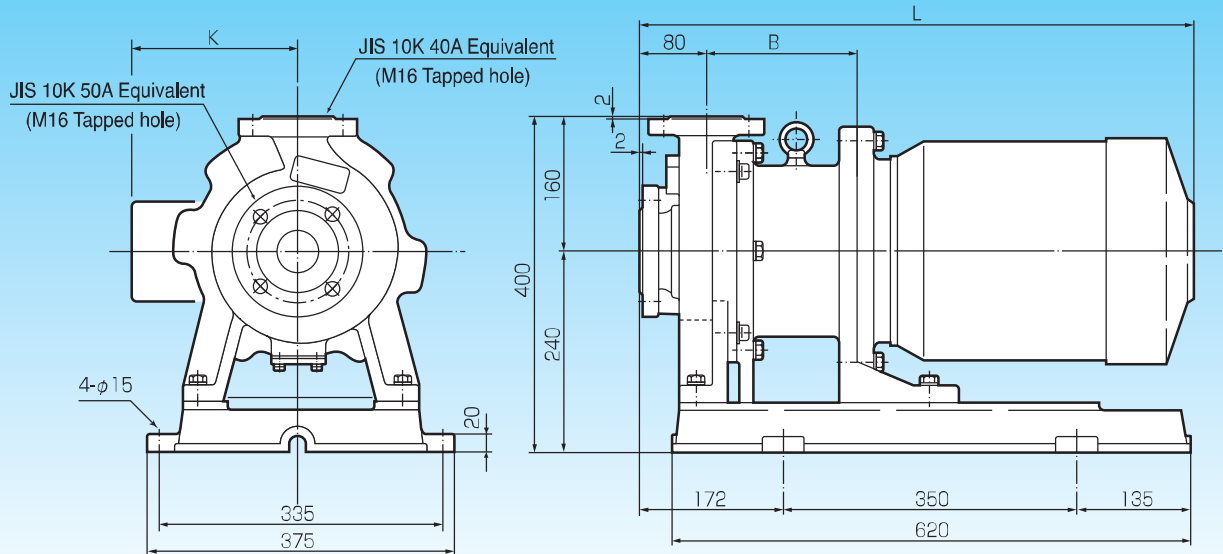

Motor Output (kW)	B	K	L	Weight (kg)
1.5 / 2.2	149	(200)	(662)	(75)
3.7	159			
5.5	179			

- Note: ① The weight of pump does not include the motor weight.
 ② The dimensions shown above are applicable when a totally-enclosed fan-cooled 2-pole motor is used. When using special motors (such as explosion-proof motors), please contact us.
 ③ The figures in parentheses are reference values.

MET Series

Construction Diagram

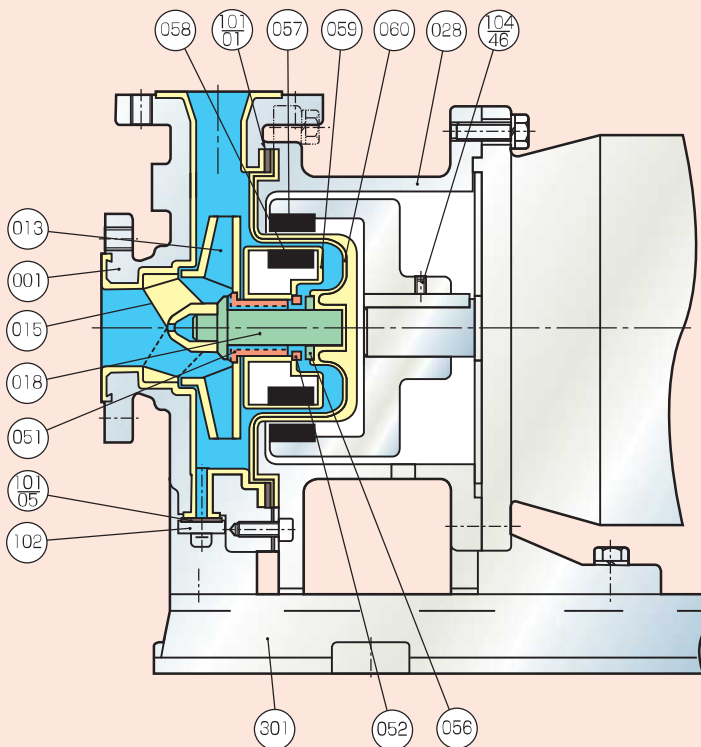

No.	Part Name	Materials
001	Casing	FCD450+PFA
013	Impeller	PFA / PVDF / ETFE
015	Shaft Support	PFA
018	Shaft	Alumina-ceramic / SiC
028	Bracket	FC200
051	Front Bearing	C-PTFE / SiC / Carbon / G-PTFE
052	Rear Bearing	C-PTFE / SiC / Carbon / G-PTFE
056	Rear Thrust Ring	Alumina-ceramic / SiC
057	Outer Magnet	Rare Earth
058	Inner Magnet	Rare Earth
059	Magnet Lining	PFA / PVDF / ETFE
060	Rear Casing	PFA (Wetted Parts)
101-01	Casing Gasket	PTFE (Jacketed)
101-05	Drain Gasket	PTFE (Jacketed)
102	Drain Flange	FC200
104-46	Outer Magnet Set Screw	SNCM
301	Base	FC200

Note: Inner Magnet (058), Magnet Lining (059), and Impeller (013) are integrated.

MTA-040 Series (Suction 40A × Discharge 25A)



Pump Specifications

- Operating Temperature: -20~120°C (Please consult us about 0°C below when used)
- Rotation Direction: Clockwise (viewed from the motor)
- Flange: JIS 10K RF (Please consult us about ANSI/DIN standard.)
- Finish Paint: Munsell 2.5B4/8 (pump body)
- Motor: IEC flanged induction motor
- Accessories: Base & Foundation bolts (M12×160L×50b)

50Hz Performance Curve & Technical Data

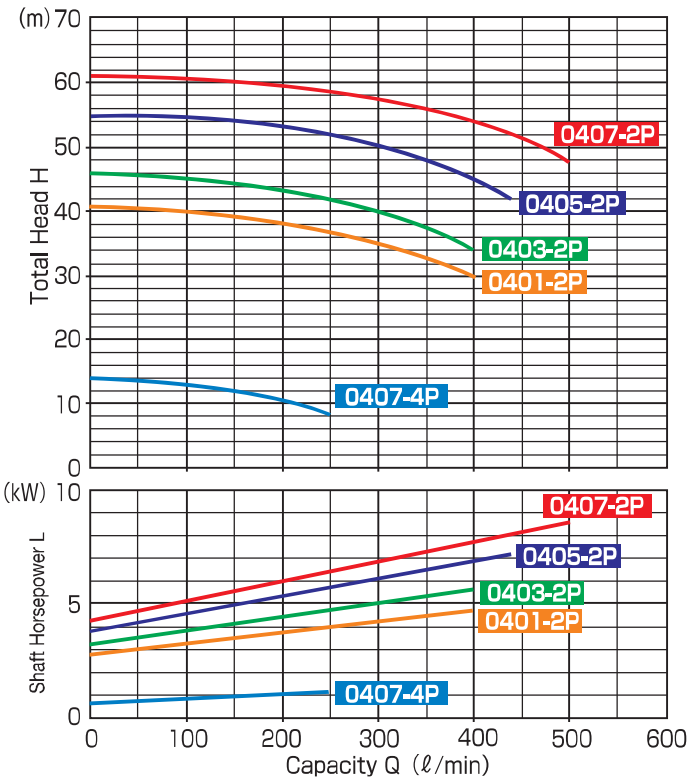

Model	Capacity (ℓ/min)	Total Head (m)	NPSH Re (m)	Motor Output (kW)
MTA-0401-2P	300	35	3.2	1.5~15
MTA-0403-2P		40		
MTA-0405-2P		50		
MTA-0407-2P		55		
MTA-0407-4P	150	10	2.0	1.5~3.7

Note: NPSH Re values shown in the table are those obtained from the maximum suction pipe diameter.

60Hz Performance Curve & Technical Data

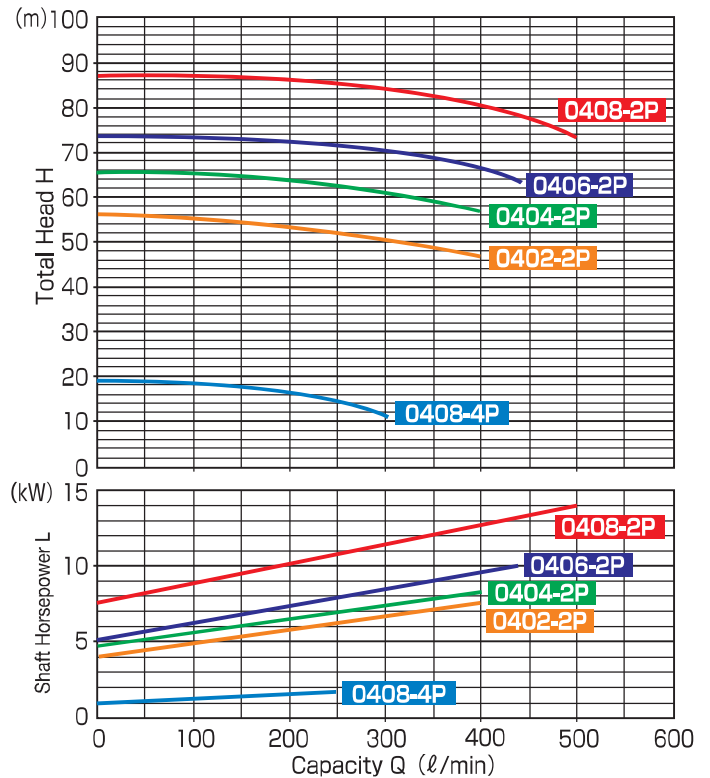

Model	Capacity (ℓ/min)	Total Head (m)	NPSH Re (m)	Motor Output (kW)
MTA-0402-2P	300	50	3.6	1.5~18.5
MTA-0404-2P		60		
MTA-0406-2P		70		
MTA-0408-2P		80		
MTA-0408-4P	150	15	2.1	1.5~3.7

Note: NPSH Re values shown in the table are those obtained from the maximum suction pipe diameter.

Pump Identification

MTA-040 1 P 02 F E 4
 ① ② ③ ④ ⑤ ⑥ ⑦ ⑧

- ① Model
- ② Suction Pipe Size
- ③ Model Number Please refer to Performance Curve
- ④ Gasket Material P : PTFE (Jacketed)
Z : Other
- ⑤ Motor Output 02 : 1.5kW 03 : 2.2kW 05 : 3.7kW
07 : 5.5kW 10 : 7.5kW 15 : 11kW
20 : 15kW 25 : 18.5kW(60Hz only)

⑥ Pump Body Material

Type	Casing	Impeller+Inner Magnet	Rear Casing
F		PFA	PFA+Eng.Plastic
Z	Other Combinations or Special Option		

⑦ Parts Material Combination

Type	Shaft	Front & Rear Thrust Rings	Mouth Ring & Bearing
B	SiC		
C		SiC	Carbon
E(Standard)		SiC	C-PTFE
H		SiC	G-PTFE
Z	Other Combinations or Special Option		

⑧ Number of Poles "4" is shown only when a 4-pole motor is installed.

Dimensions

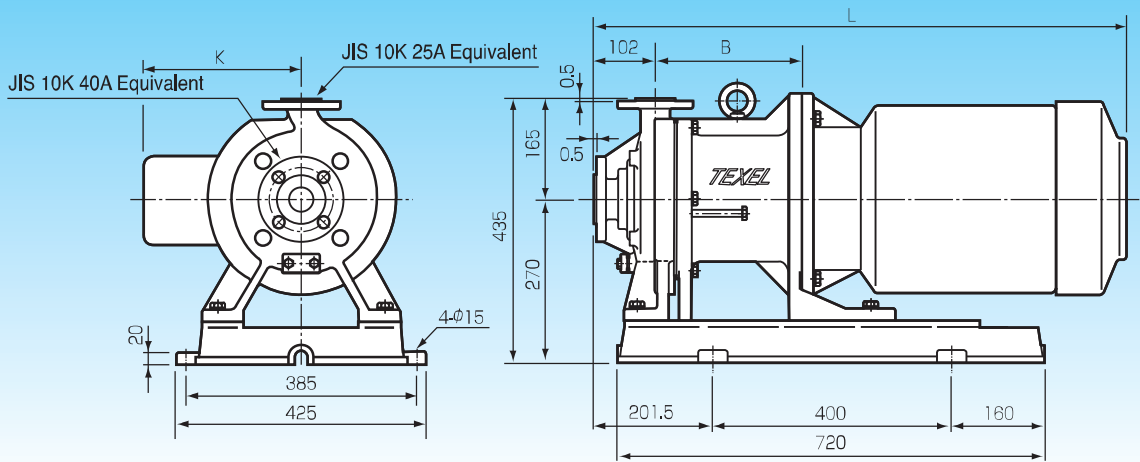

Motor Output (kW)	B	K	L	Weight (kg)
1.5 / 2.2	188	(260)	(888)	(105)
3.7	198			
5.5 / 7.5	218			
11 / 15 / 18.5	248			

- Note: ① The weight of pump does not include the motor weight.
 ② The dimensions shown above are applicable when a totally-enclosed fan-cooled 2-pole motor is used. When using special motors (such as explosion-proof motors), please contact us.
 ③ The figures in parentheses are reference values.

Construction Diagram

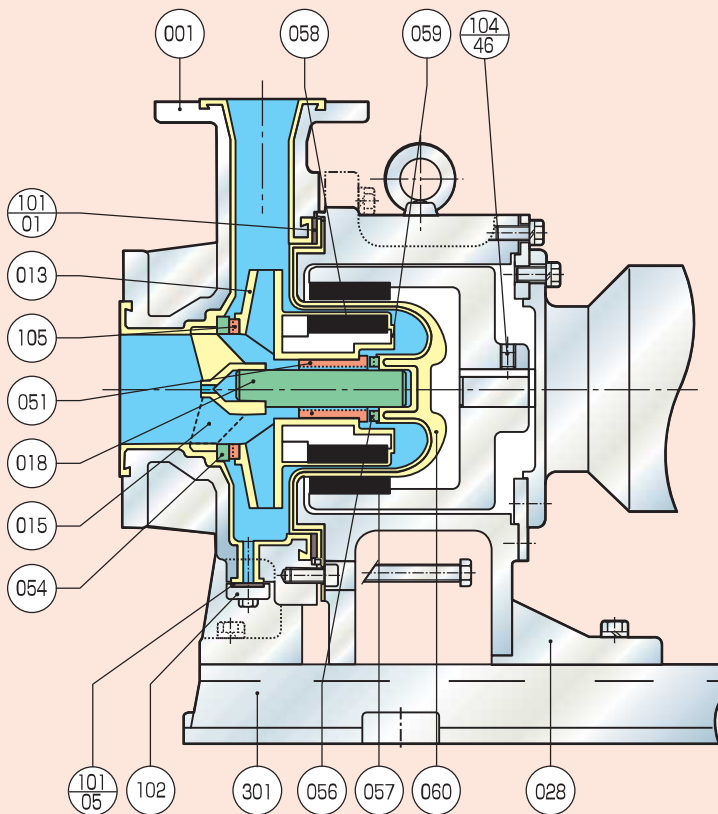

No.	Part Name	Materials
001	Casing	FCD450 + PFA
013	Impeller	PFA
015	Shaft Support	PFA
018	Shaft	SiC
028	Bracket	FC200
051	Bearing	C-PTFE / SiC / Carbon / G-PTFE
054	Front Thrust Ring	SiC
056	Rear Thrust Ring	SiC
057	Outer Magnet	Rare Earth
058	Inner Magnet	Rare Earth
059	Magnet Lining	PFA
060	Rear Casing	PFA (Wetted Parts)
101-01	Casing Gasket	PTFE (Jacketed)
101-05	Drain Gasket	PTFE (Jacketed)
102	Drain Flange	FC200
104-46	Outer Magnet Set Screw	SNCM
105	Mouth Ring	C-PTFE / SiC / Carbon / G-PTFE
301	Base	FC200

Note: Inner Magnet (058), Magnet Lining (059), and Impeller (013) are integrated.

MTA-080 Series (Suction 80A × Discharge 50A)



Pump Specifications

- Operating Temperature -20~120°C (Please consult us about 0°C below when used)
- Rotation Direction Clockwise (viewed from the motor)
- Flange JIS 10K RF (Please consult us about ANSI/DIN standard.)
- Finish Paint Munsell 2.5B4/8 (pump body)
- Motor IEC flanged induction motor
- Accessories Base & Foundation bolts (M12×160L×50b)

50Hz Performance Curve & Technical Data

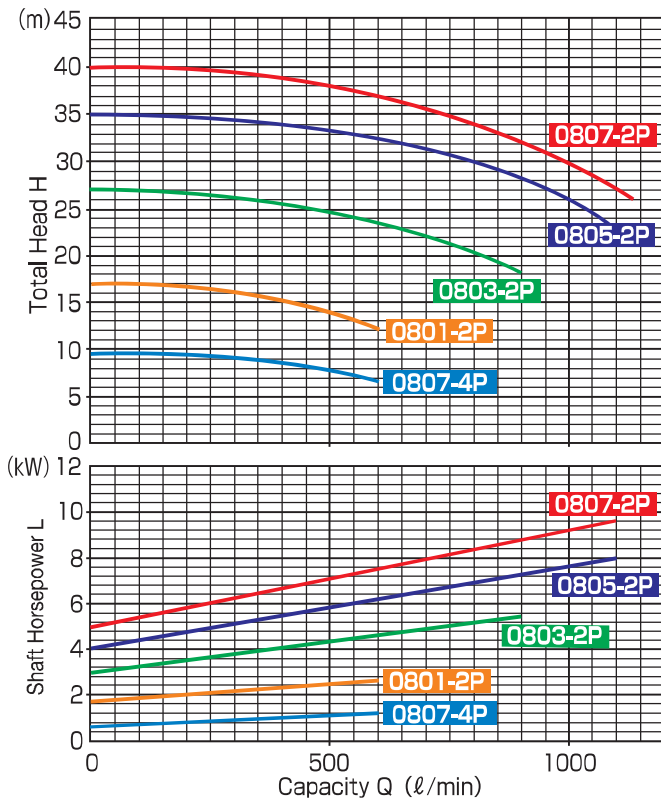

Model	Capacity (ℓ/min)	Total Head (m)	NPSH Re (m)	Motor Output (kW)
MTA-0801-2P	700	10	4.3	1.5~15
MTA-0803-2P	800	20	5.0	
MTA-0805-2P		30		
MTA-0807-2P	34			
MTA-0807-4P	400	8	2.4	1.5~3.7

Note: NPSH Re values shown in the table are those obtained from the maximum suction pipe diameter.

60Hz Performance Curve & Technical Data

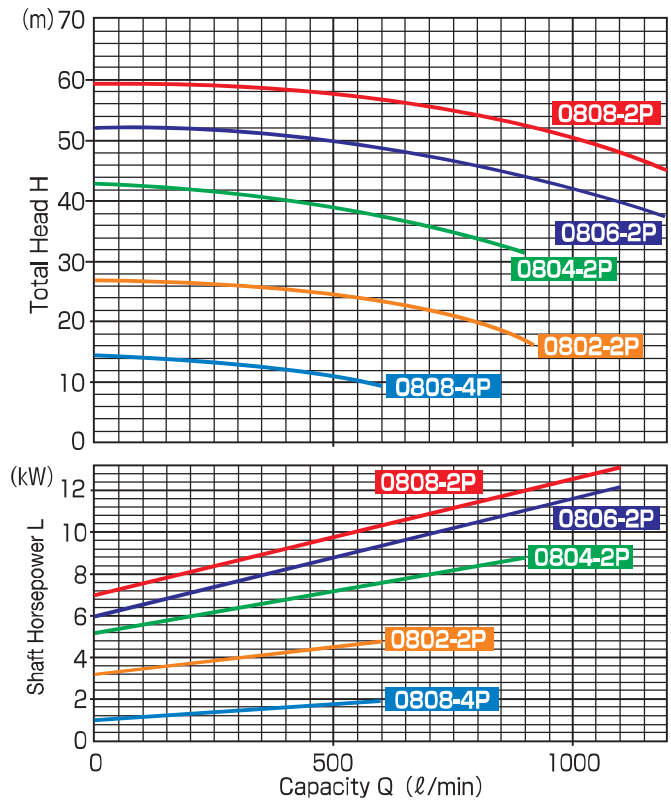

Model	Capacity (ℓ/min)	Total Head (m)	NPSH Re (m)	Motor Output (kW)
MTA-0802-2P	800	20	5.2	1.5~18.5
MTA-0804-2P	1000	30	6.8	
MTA-0806-2P		40		
MTA-0808-2P	50			
MTA-0808-4P	500	10	2.6	1.5~3.7

Note: NPSH Re values shown in the table are those obtained from the maximum suction pipe diameter.

Pump Identification

MTA-080 1 P 02 F E 4

① ② ③ ④ ⑤ ⑥ ⑦ ⑧

- ① Model
- ② Suction Pipe Size
- ③ Model Number Please refer to Performance Curve
- ④ Gasket Material P : PTFE (Jacketed)
Z : Other
- ⑤ Motor Output 02 : 1.5kW 03 : 2.2kW 05 : 3.7kW
07 : 5.5kW 10 : 7.5kW 15 : 11kW
20 : 15kW 25 : 18.5kW(60Hz only)

⑥ Pump Body Material

Type	Casing	Impeller+ Inner Magnet	Rear Casing
F	PFA	PFA	PFA + Eng. Plastic
Z			Other Combinations or Special Option

⑦ Parts Material Combination

Type	Shaft	Front & Rear Thrust Rings	Mouth Ring & Bearing
B	SIC	SIC	Carbon
C			Carbon
E (Standard)	SIC	SIC	C-PTFE
H	SIC	SIC	G-PTFE
Z	Other Combinations or Special Option		

⑧ Number of Poles "4" is shown only when a 4-pole motor is installed.

MTA Series

Dimensions

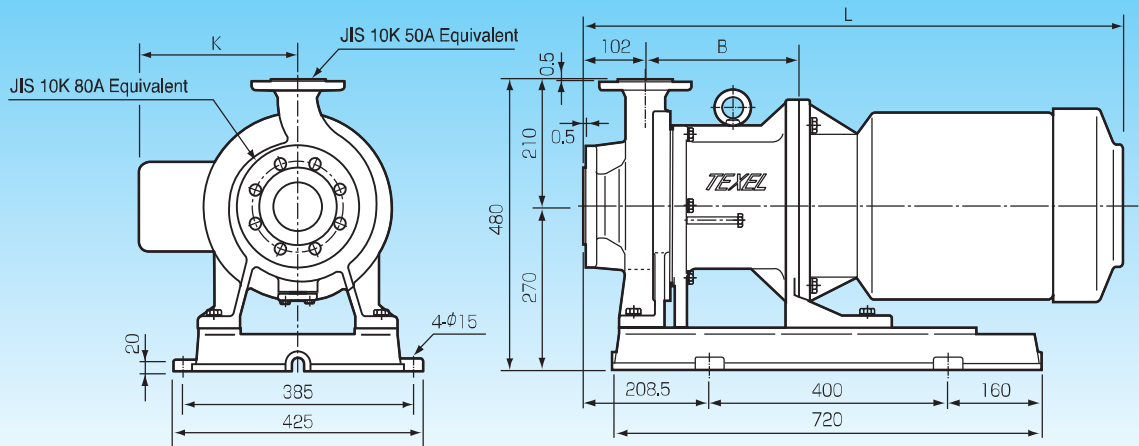

Motor Output (kW)	B	K	L	Weight (kg)
1.5 / 2,2	195	(260)	(895)	(108)
3.7	205			
5.5 / 7,5	225			
11 / 15 / 18,5	255			

Note: ① The weight of pump does not include the motor weight.
 ② The dimensions shown above are applicable when a totally-enclosed fan-cooled 2-pole motor is used.
 When using special motors (such as explosion-proof motors), please contact us.
 ③ The figures in parentheses are reference values.

Construction Diagram

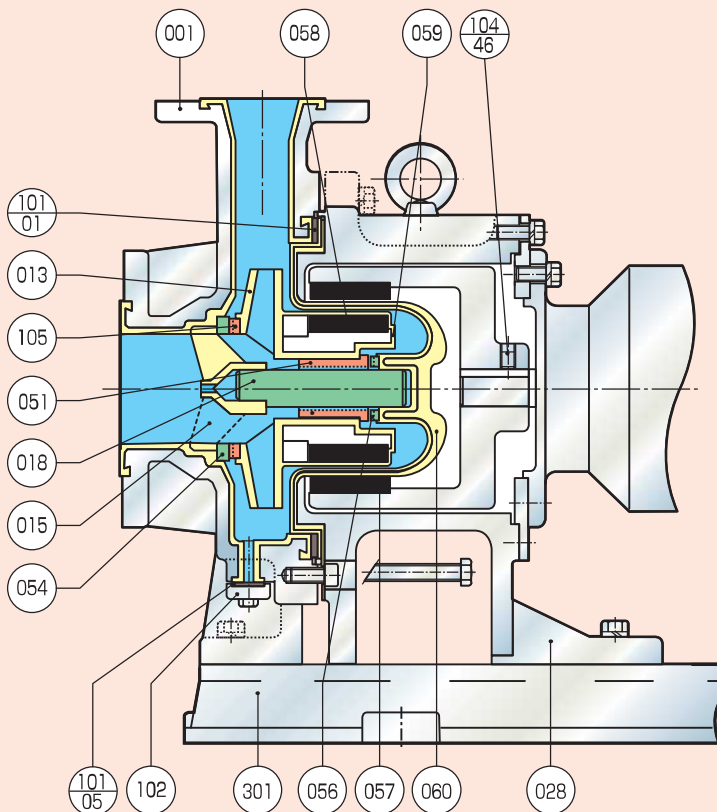

No.	Part Name	Materials
001	Casing	FCD450 + PFA
013	Impeller	PFA
015	Shaft Support	PFA
018	Shaft	SiC
028	Bracket	FC200
051	Bearing	C-PTFE / SiC / Carbon / G-PTFE
054	Front Thrust Ring	SiC
056	Rear Thrust Ring	SiC
057	Outer Magnet	Rare Earth
058	Inner Magnet	Rare Earth
059	Magnet Lining	PFA
060	Rear Casing	PFA (Wetted Parts)
101-01	Casing Gasket	PTFE (Jacketed)
101-05	Drain Gasket	PTFE (Jacketed)
102	Drain Flange	FC200
104-46	Outer Magnet Set Screw	SNCM
105	Mouth Ring	C-PTFE / SiC / Carbon / G-PTFE
301	Base	FC200

Note: Inner Magnet (058), Magnet Lining (059), and Impeller (013) are integrated.

MTA-100 Series (Suction 100A×Discharge 80A)



Pump Specifications

- Operating Temperature -20~120°C (Please consult us about 0°C below when used)
- Rotation Direction Clockwise (viewed from the motor)
- Flange JIS 10K RF (Please consult us about ANSI/DIN standard,)
- Finish Paint Munsell 2,5B4/8(pump body)
- Motor IEC flanged induction motor
- Accessories Base & Foundation bolts (M12×160L×50b)

50Hz Performance Curve & Technical Data

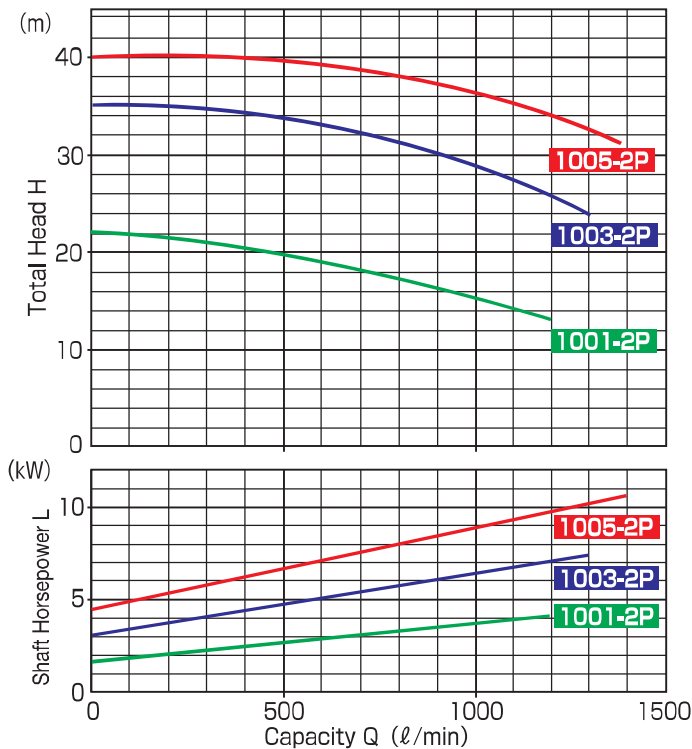

Model	Capacity (ℓ/min)	Total Head (m)	NPSH Re (m)	Motor Output (kW)
MTA-1001-2P	1000	15	4.5	5.5~15
MTA-1003-2P	1200	25	5.8	
MTA-1005-2P		30		

Note: NPSH Re values shown in the table are those obtained from the maximum suction pipe diameter.

60Hz Performance Curve & Technical Data

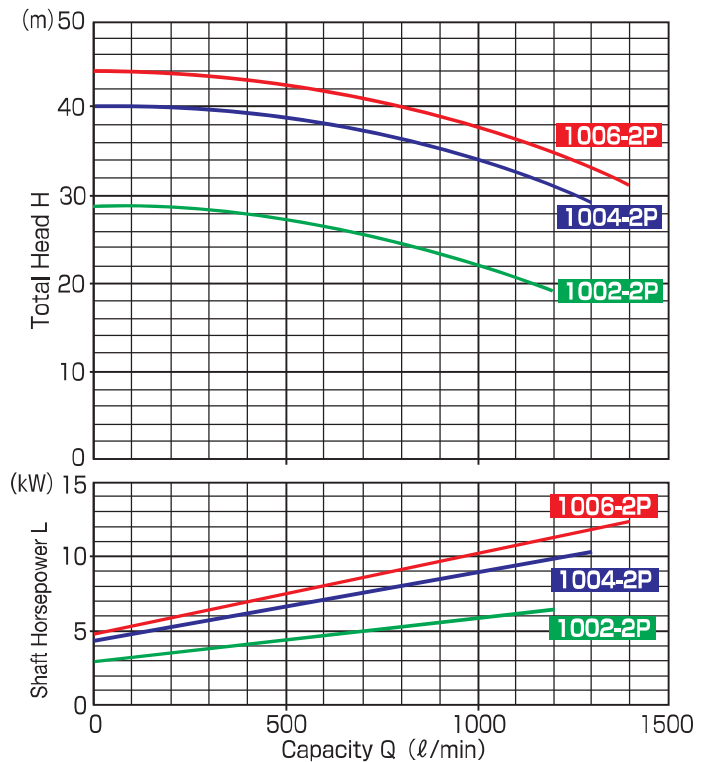

Model	Capacity (ℓ/min)	Total Head (m)	NPSH Re (m)	Motor Output (kW)
MTA-1002-2P	1000	20	5.2	5.5~18.5
MTA-1004-2P	1200	30	6.6	
MTA-1006-2P		35		

Note: NPSH Re values shown in the table are those obtained from the maximum suction pipe diameter.

Pump Identification

MTA-100 1 P 07 F E

① ② ③ ④ ⑤ ⑥ ⑦

- ① Model
- ② Suction Pipe Size
- ③ Model Number Please refer to Performance Curve
- ④ Gasket Material P : PTFE (Jacketed)
Z : Other
- ⑤ Motor Output 07 : 5.5kW 10 : 7.5kW 15 : 11kW
20 : 15kW 25 : 18.5kW(60Hz only)

⑥ Pump Body Material

Type	Casing	Impeller+Inner Magnet	Rear Casing
F	PFA		PFA+Eng.Plastic
Z	Other Combinations or Special Option		

⑦ Parts Material Combination

Type	Shaft	Front & Rear Thrust Rings	Mouth Ring & Bearing
B	SiC		
C	SiC		Carbon
E (Standard)	SiC		C-PTFE
H	SiC		G-PTFE
Z	Other Combinations or Special Option		

Dimensions

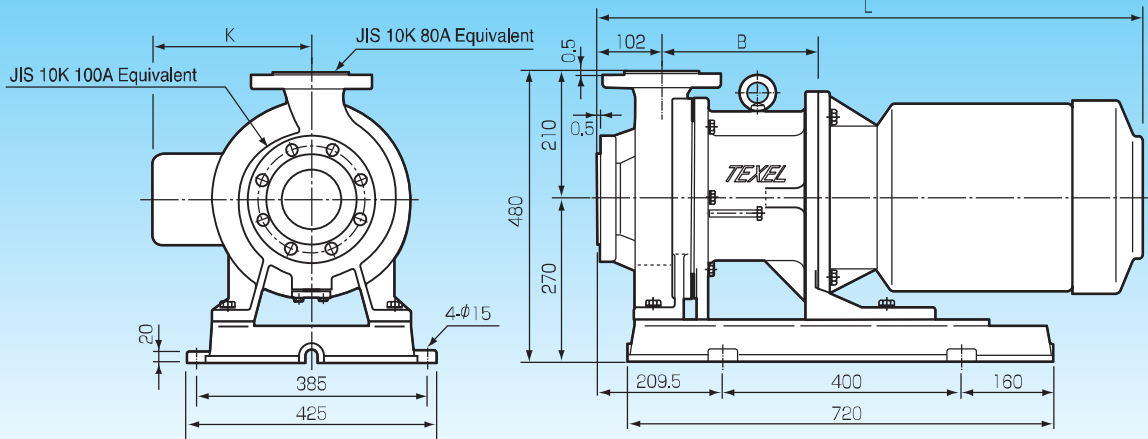

Motor Output (kW)	B	K	L	Weight (kg)
5.5 / 7.5	235	(270)	(920)	(115)
11 / 15 / 18,5	265			

- Note: ① The weight of pump does not include the motor weight.
 ② The dimensions shown above are applicable when a totally-enclosed fan-cooled motor is used.
 When using special motors (such as explosion-proof motors), please contact us.
 ③ The figures in parentheses are reference values.

Construction Diagram

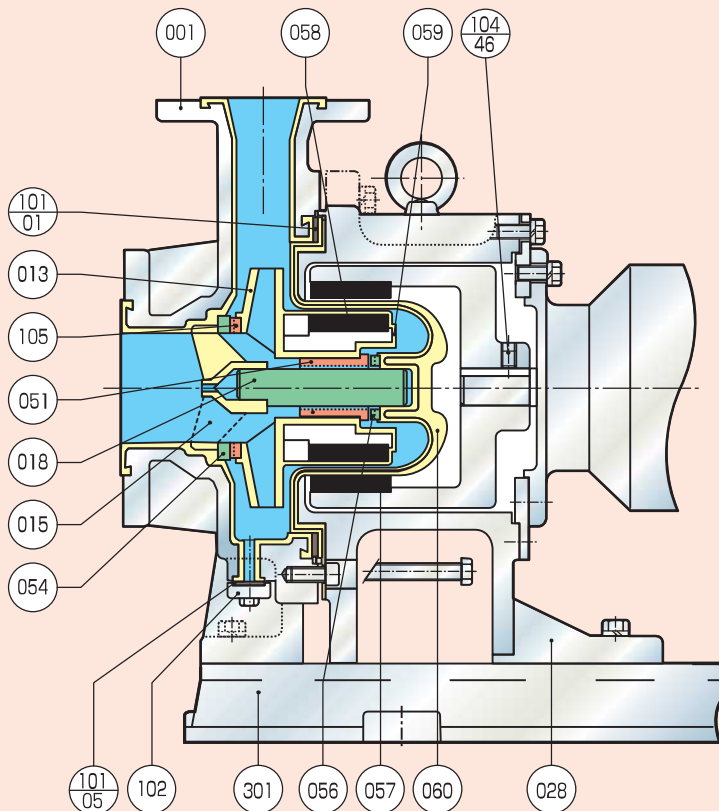

No.	Part Name	Materials
001	Casing	FCD450+PFA
013	Impeller	PFA
015	Shaft Support	PFA
018	Shaft	SiC
028	Bracket	FC200
051	Bearing	C-PTFE / SiC / Carbon / G-PTFE
054	Front Thrust Ring	SiC
056	Rear Thrust Ring	SiC
057	Outer Magnet	Rare Earth
058	Inner Magnet	Rare Earth
059	Magnet Lining	PFA
060	Rear Casing	PFA (Wetted Parts)
101-01	Casing Gasket	PTFE (Jacketed)
101-05	Drain Gasket	PTFE (Jacketed)
102	Drain Flange	FC200
104-46	Outer Magnet Set Screw	SNCM
105	Mouth Ring	C-PTFE / SiC / Carbon / G-PTFE
301	Base	FC200

Note: Inner Magnet (058), Magnet Lining (059), and Impeller (013) are integrated.

MTA-101 Series (Suction 100A × Discharge 80A)



Pump Specifications

- Operating Temperature -20~100°C (Please consult us about 0°C below when used)
- Rotation Direction Clockwise (viewed from the motor)
- Flange JIS 10K RF (Please consult us about ANSI/DIN standard.)
- Finish Paint Munsell 2.5B4/8(pump body)
- Motor IEC flanged induction motor
- Accessories Base & Foundation bolts (M16×200L×63b)

50Hz Performance Curve & Technical Data

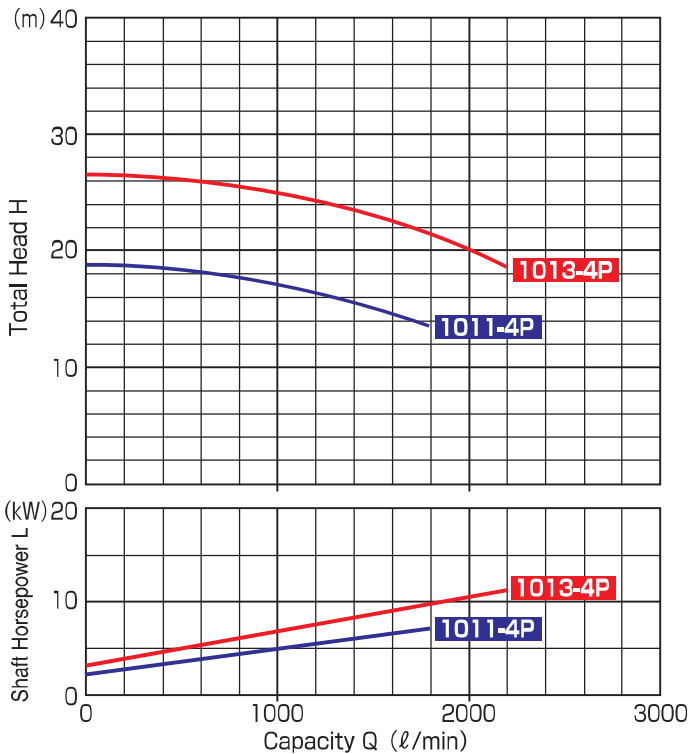

Model	Capacity (l/min)	Total Head (m)	NPSH Re (m)	Motor Output (kW)
MTA-1011-4P	1500	15	3.2	11~30
MTA-1013-4P	2000	20	5.3	

Note: NPSH Re values shown in the table are those obtained from the maximum suction pipe diameter.

60Hz Performance Curve & Technical Data

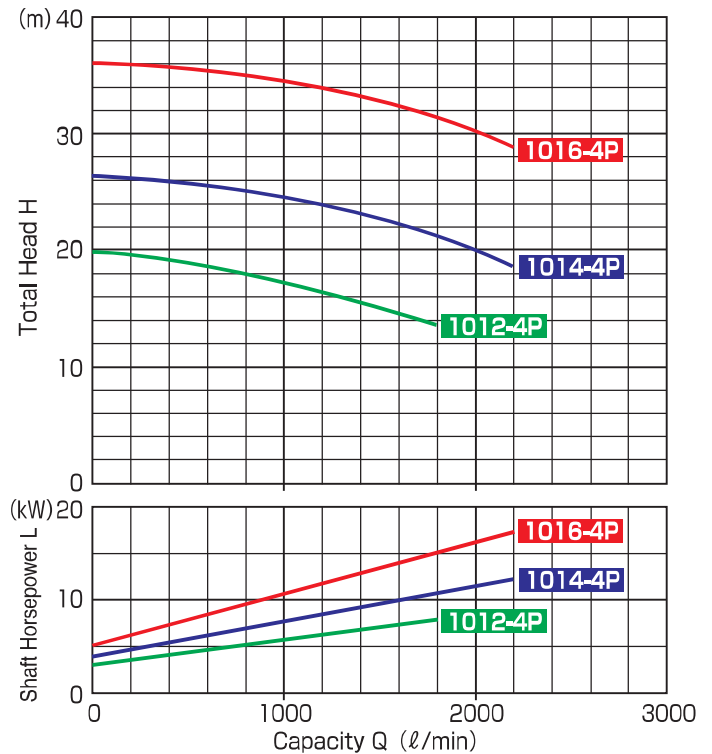

Model	Capacity (l/min)	Total Head (m)	NPSH Re (m)	Motor Output (kW)
MTA-1012-4P	1500	15	3.2	11~37
MTA-1014-4P	2000	20	5.3	
MTA-1016-4P		30		

Note: NPSH Re values shown in the table are those obtained from the maximum suction pipe diameter.

Pump Identification

MTA-101 1 P 15 F A 4 L Z

① ② ③ ④ ⑤ ⑥ ⑦ ⑧ ⑨ ⑩

- ① Model
- ② Suction Pipe Size
- ③ Model Number Please refer to Performance Curve
- ④ Gasket Material P : PTFE (Jacketed)
Z : Other
- ⑤ Motor Output 15:11kW 20:15kW 25:18.5kW
30:22kW 40:30kW 50:37kW
- ⑥ Pump Body Material

Type	Casing	Impeller + Inner Magnet	Rear Casing
F		PFA	PFA + Eng. Plastic

Parts Material Combination

Type	Shaft	Front & Rear Thrust Rings	Mouth Ring & Bearing
A	Alumina-ceramic		C-PTFE
B	SiC		
C	SiC		Carbon
E	SiC		C-PTFE
F	Alumina-ceramic		Carbon
G	Alumina-ceramic		G-PTFE
H	SiC		G-PTFE
Z	Other Combinations or Special Option		

- ⑧ Number of Poles "4" is shown.
- ⑨ Construction Identification "L" is shown for long couplings only.
- ⑩ Custom Specifications "Z" is shown when non-standard parts are used.

Dimensions

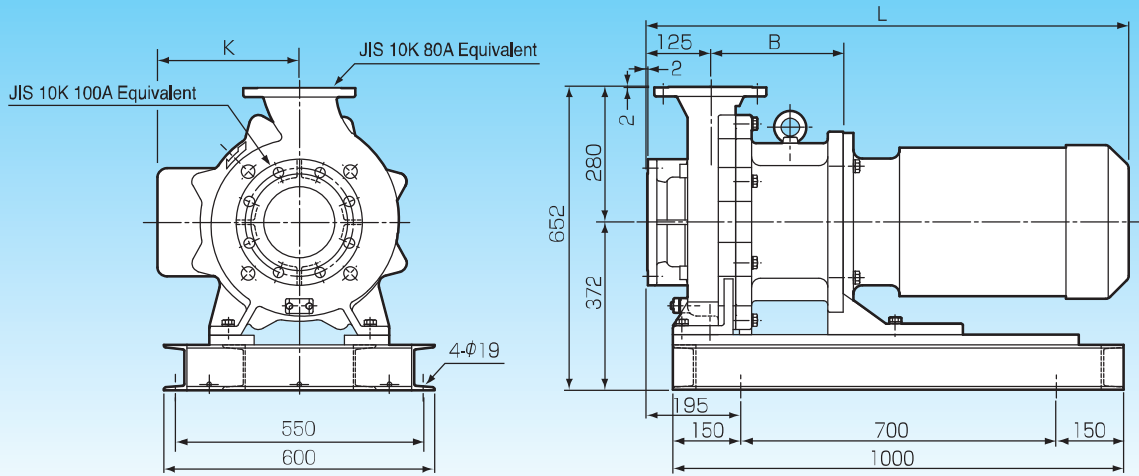

Motor Output (kW)	B	K	L	Weight (kg)
11~30	298	(314)	(1068.5)	(275)
37	328			

- Note: ① The weight of pump does not include the motor weight.
 ② The dimensions shown above are applicable when a totally-enclosed fan-cooled motor is used.
 When using special motors (such as explosion-proof motors), please contact us.
 ③ The figures in parentheses are reference values.

Construction Diagram

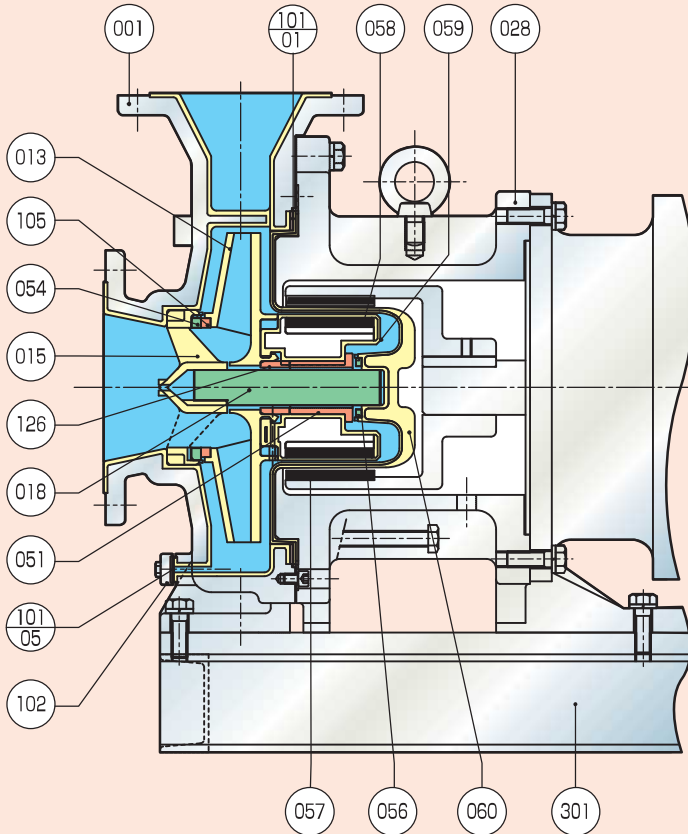

No.	Part Name	Materials
001	Casing	FCD450+PFA
013	Impeller	PFA
015	Shaft Support	PFA
018	Shaft	Alumina-ceramic / SiC
028	Bracket	FC200
051	Bearing	C-PTFE/G-PTFE/SiC/Carbon
054	Front Thrust Ring	Alumina-ceramic / SiC
056	Rear Thrust Ring	Alumina-ceramic / SiC
057	Outer Magnet	Rare Earth
058	Inner Magnet	Rare Earth
059	Magnet Lining	PFA
060	Rear Casing	PFA(Wetted Parts)
101-01	Casing Gasket	PTFE
101-05	Drain Gasket	PTFE(Jacketed)
102	Drain Flange	FC200
105	Mouth Ring	C-PTFE/G-PTFE/SiC/Carbon
126	Impeller Set Ring	PTFE
301	Base	SS400

Note: Inner Magnet (058) and Magnet Lining (059) are integrated and engaged with Impeller (013).

MTA-125 Series (Suction 125A × Discharge 100A)



Pump Specifications

- Operating Temperature -20~100°C (Please consult us about 0°C below when used)
- Rotation Direction Clockwise (viewed from the motor)
- Flange JIS 10K RF (Please consult us about ANSI/DIN standard.)
- Finish Paint Munsell 2.5B4/8(pump body)
- Motor IEC flanged induction motor
- Accessories Base & Foundation bolts (M16×200L×63b)

50Hz Performance Curve & Technical Data

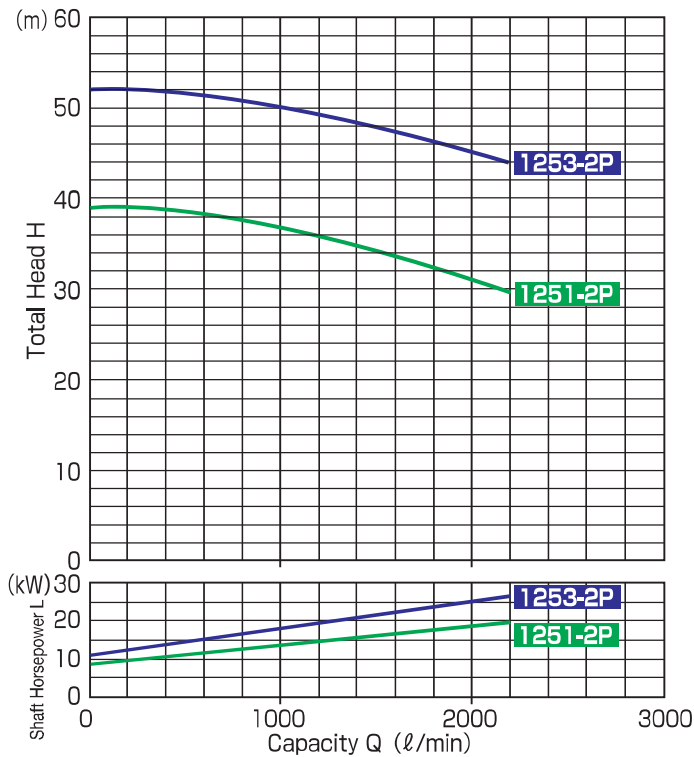

Model	Capacity (l/min)	Total Head (m)	NPSH Re (m)	Motor Output (kW)
MTA-1251-2P	2000	30	4.4	11~45
MTA-1253-2P		40		

Note: NPSH Re value shown in the table is that obtained from the maximum suction pipe diameter.

60Hz Performance Curve & Technical Data

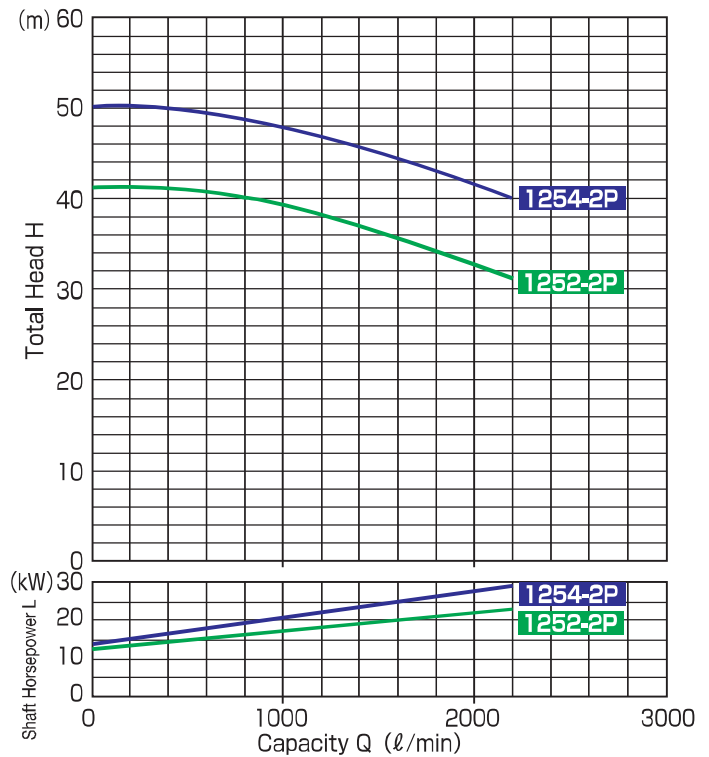

Model	Capacity (l/min)	Total Head (m)	NPSH Re (m)	Motor Output (kW)
MTA-1252-2P	2000	30	4.4	11~45
MTA-1254-2P		40		

Note: NPSH Re value shown in the table is that obtained from the maximum suction pipe diameter.

Pump Identification

MTA-125 1 P 15 FA LZ
 ① ② ③ ④ ⑤ ⑥ ⑦ ⑧ ⑨

- ① Model ② Suction Pipe Size
- ③ Model Number Please refer to Performance Curve
- ④ Gasket Material P : PTFE (Jacketed)
- ⑤ Motor Output 15:11kW 20:15kW 25:18.5kW
30:22kW 40:30kW 50:37kW 60:45kW
- ⑥ Pump Body Material

Type	Casing	Impeller+Inner Magnet	Rear Casing
F		PFA	PFA+Eng.Plastic

⑦ Parts Material Combination

Type	Shaft	Front & Rear Thrust Rings	Mouth Ring & Bearing
A	Alumina-ceramic		C-PTFE
B	SiC		
C		SiC	Carbon
E		SiC	C-PTFE
F	Alumina-ceramic		Carbon
G	Alumina-ceramic		G-PTFE
H		SiC	G-PTFE
Z	Other Combinations or Special Option		

- ⑧ Construction Identification "L" is shown for long couplings only.
- ⑨ Custom Specifications "Z" is shown when non-standard parts are used.

Dimensions

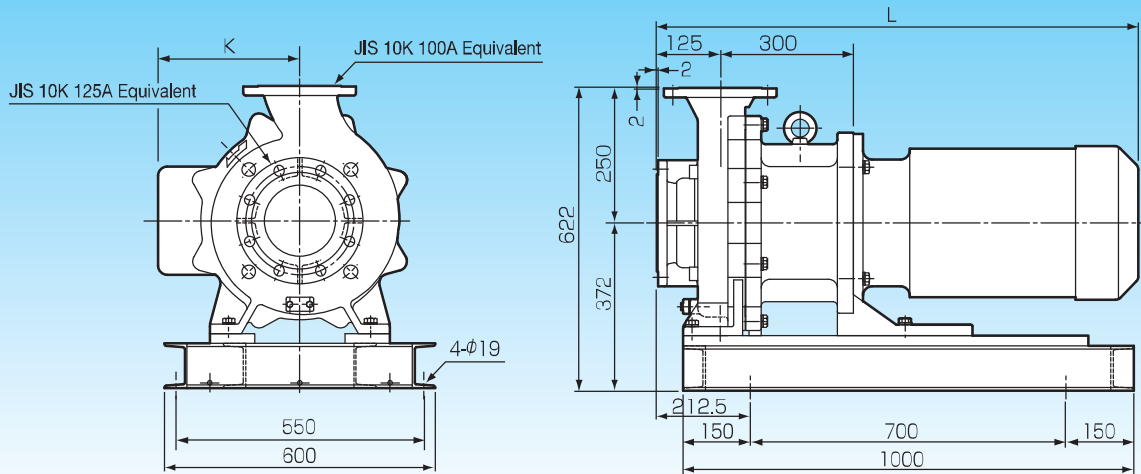

Motor Output (kW)	K	L	Weight (kg)
11~45	(314)	(1068.5)	(255)

- Note: ① The weight of pump does not include the motor weight.
 ② The dimensions shown above are applicable when a totally-enclosed fan-cooled motor is used.
 When using special motors (such as explosion-proof motors), please contact us.
 ③ The figures in parentheses are reference values.

Construction Diagram

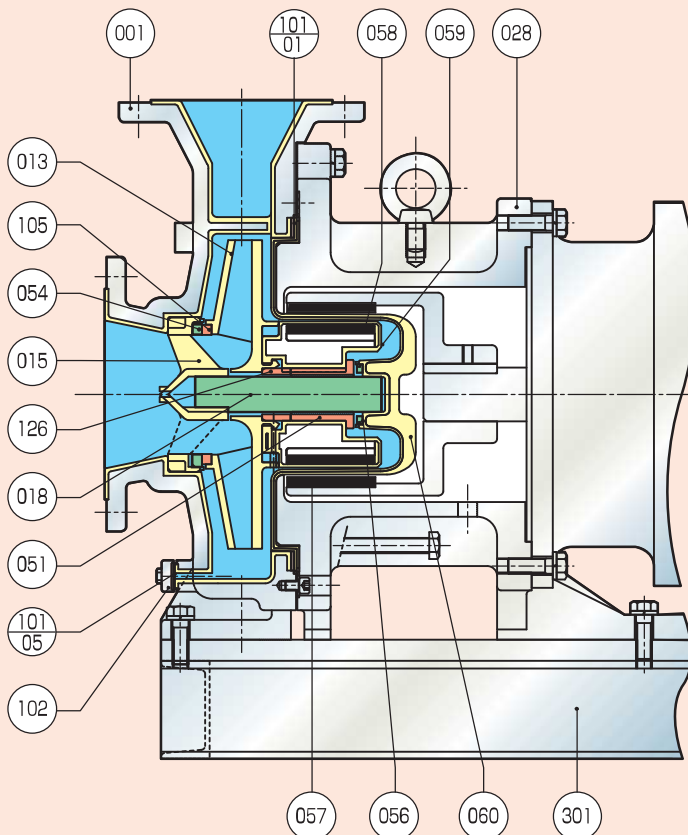

No.	Part Name	Materials
001	Casing	FCD450+PFA
013	Impeller	PFA
015	Shaft Support	PFA
018	Shaft	Alumina-ceramic / SiC
028	Bracket	FC200
051	Bearing	C-PTFE/G-PTFE/SiC/Carbon
054	Front Thrust Ring	Alumina-ceramic / SiC
056	Rear Thrust Ring	Alumina-ceramic / SiC
057	Outer Magnet	Rare Earth
058	Inner Magnet	Rare Earth
059	Magnet Lining	PFA
060	Rear Casing	PFA(Wetted Parts)
101-01	Casing Gasket	PTFE
101-05	Drain Gasket	PTFE(Jacketed)
102	Drain Flange	FC200
105	Mouth Ring	C-PTFE/G-PTFE/SiC/Carbon
126	Impeller Set Ring	PTFE
301	Base	SS400

Note: Inner Magnet (058) and Magnet Lining (059) are integrated and engaged with Impeller (013).

MTA-150 Series (Suction 150A × Discharge 125A)



Pump Specifications

- Operating Temperature -20~100°C (Please consult us about 0°C below when used)
- Rotation Direction Clockwise (viewed from the motor)
- Flange JIS 10K RF (Please consult us about ANSI/DIN standard.)
- Finish Paint Munsell 2,5B4/8(pump body)
- Motor IEC flanged induction motor
- Accessories Base & Foundation bolts (M16×200L×63b)

50Hz Performance Curve & Technical Data

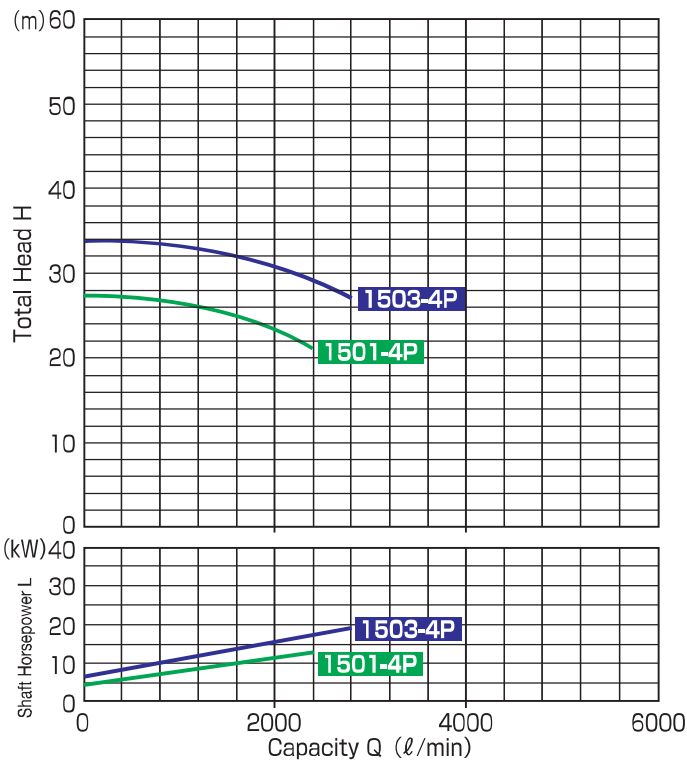

Model	Capacity (l/min)	Total Head (m)	NPSH Re (m)	Motor Output (kW)
MTA-1501-4P	2000	23	3.0	11~30
MTA-1503-4P		30		

Note: NPSH Re value shown in the table is that obtained from the maximum suction pipe diameter.

60Hz Performance Curve & Technical Data

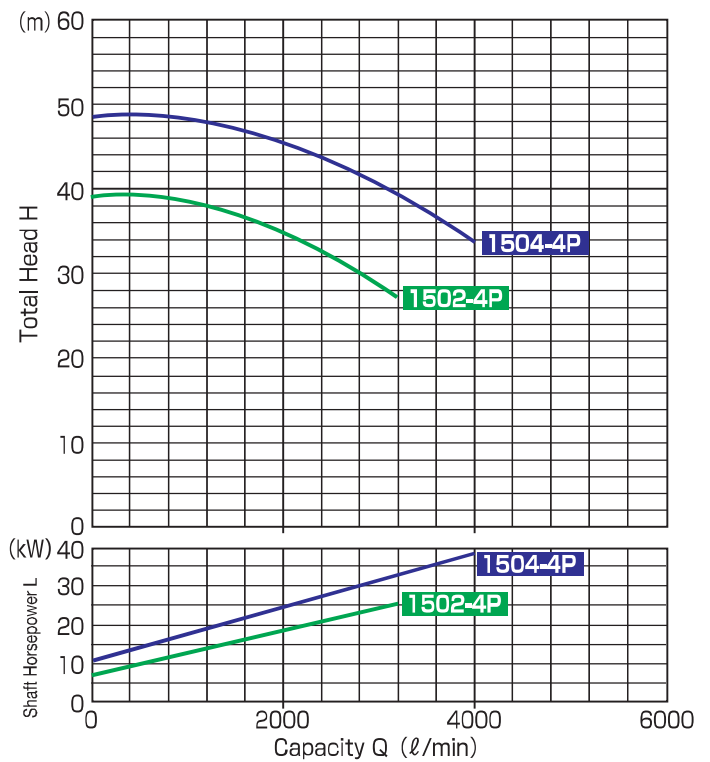

Model	Capacity (l/min)	Total Head (m)	NPSH Re (m)	Motor Output (kW)
MTA-1502-4P	2500	32	4.2	11~37
MTA-1504-4P	3000	40	5.5	

Note: NPSH Re values shown in the table are those obtained from the maximum suction pipe diameter.

Pump Identification

MTA-150 1 P 15 F A 4 L Z

① ② ③ ④ ⑤ ⑥ ⑦ ⑧ ⑨ ⑩

- ① Model
- ② Suction Pipe Size
- ③ Model Number Please refer to Performance Curve
- ④ Gasket Material P : PTFE (Jacketed)
- ⑤ Motor Output 15:11kW 20:15kW 25:18.5kW
30:22kW 40:30kW 50:37kW
- ⑥ Pump Body Material

Type	Casing	Impeller+Inner Magnet	Rear Casing
F		PFA	PFA+Eng.Plastic

⑦ Parts Material Combination

Type	Shaft	Front & Rear Thrust Rings	Mouth Ring & Bearing
A	Alumina-ceramic		C-PTFE
B	SiC		
C	SiC		Carbon
E	SiC		C-PTFE
F	Alumina-ceramic		Carbon
G	Alumina-ceramic		G-PTFE
H	SiC		G-PTFE
Z	Other Combinations or Special Option		

- ⑧ Number of Poles "4" is shown.
- ⑨ Construction Identification "L" is shown for long couplings only.
- ⑩ Custom Specifications "Z" is shown when non-standard parts are used.

Dimensions

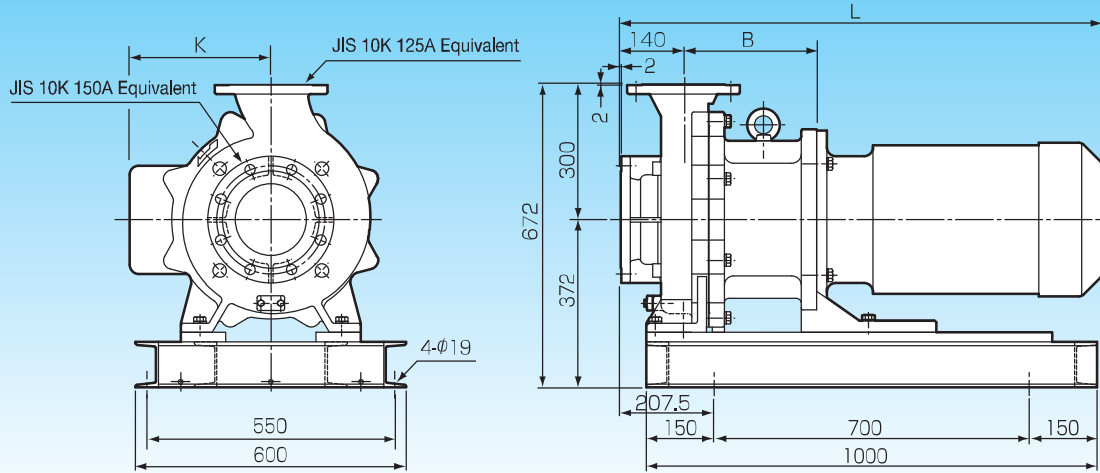

Motor Output (kW)	B	K	L	Weight (kg)
11~30	295.5	(314)	(1068.5)	(275)
37	325.5			

- Note: ① The weight of pump does not include the motor weight.
 ② The dimensions shown above are applicable when a totally-enclosed fan-cooled motor is used. When using special motors (such as explosion-proof motors), please contact us.
 ③ The figures in parentheses are reference values.

Construction Diagram

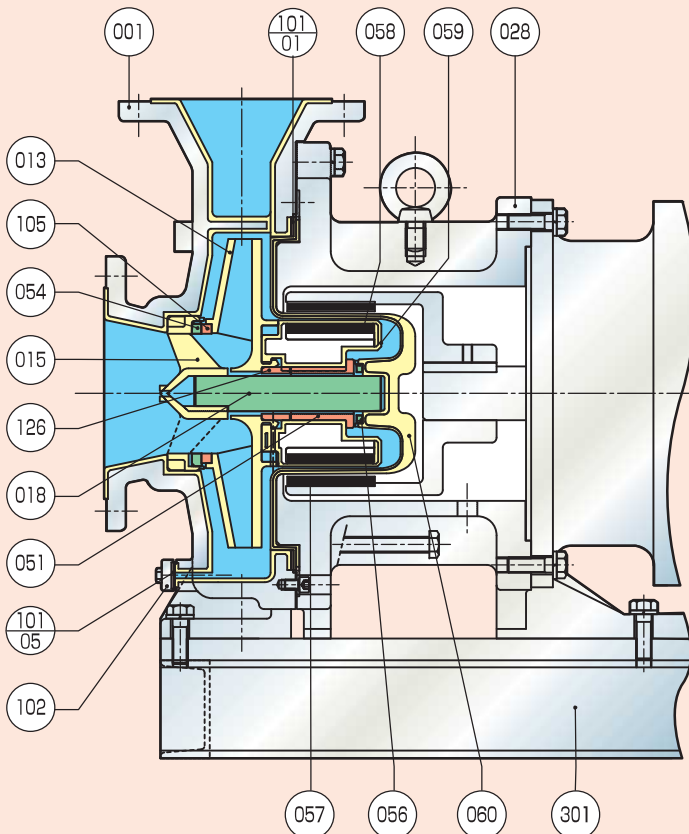

No.	Part Name	Materials
001	Casing	FCD450+PFA
013	Impeller	PFA
015	Shaft Support	PFA
018	Shaft	Alumina-ceramic / SiC
028	Bracket	FC200
051	Bearing	C-PTFE/G-PTFE/SiC/Carbon
054	Front Thrust Ring	Alumina-ceramic / SiC
056	Rear Thrust Ring	Alumina-ceramic / SiC
057	Outer Magnet	Rare Earth
058	Inner Magnet	Rare Earth
059	Magnet Lining	PFA
060	Rear Casing	PFA(Wetted Parts)
101-01	Casing Gasket	PTFE
101-05	Drain Gasket	PTFE(Jacketed)
102	Drain Flange	FC200
105	Mouth Ring	C-PTFE/G-PTFE/SiC/Carbon
126	Impeller Set Ring	PTFE
301	Base	SS400

Note: Inner Magnet (058) and Magnet Lining (059) are integrated and engaged with Impeller (013).

MTA-200 Series (Suction 200A × Discharge 150A)



Pump Specifications

- Operating Temperature 0~90°C
- Rotation Direction Clockwise (viewed from the motor)
- Flange JIS 10K RF (Please consult us about ANSI/DIN standard.)
- Finish Paint Munsell 2.5B4/8 (pump body)
- Motor IEC flanged induction motor
- Accessories Base & Foundation bolts (M16 × 200L × 63b)

50Hz Performance Curve & Technical Data

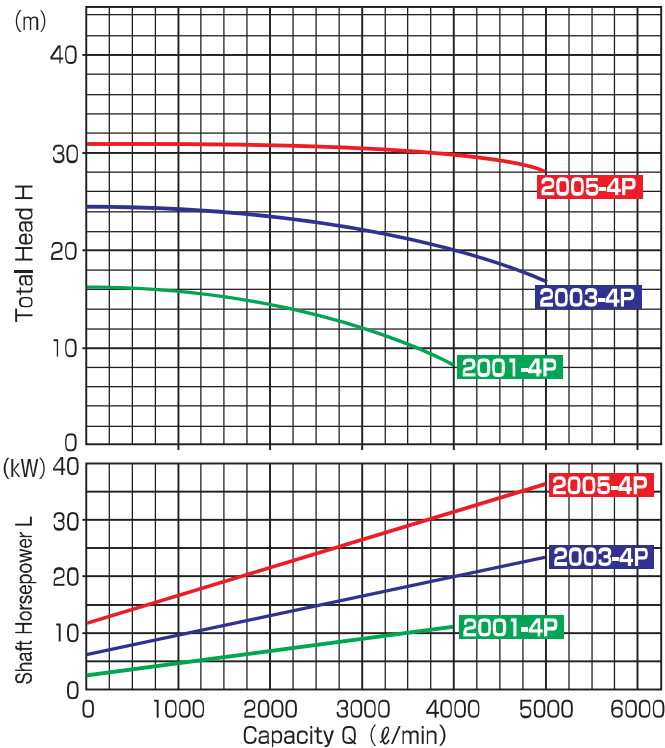

Model	Capacity (ℓ/min)	Total Head (m)	NPSH Re (m)	Motor Output (kW)
MTA-2001-4P	3000	12	3.3	11~45
MTA-2003-4P	4000	20	3.5	
MTA-2005-4P		30		

Note: NPSH Re values shown in the table are those obtained from the maximum suction pipe diameter.

60Hz Performance Curve & Technical Data

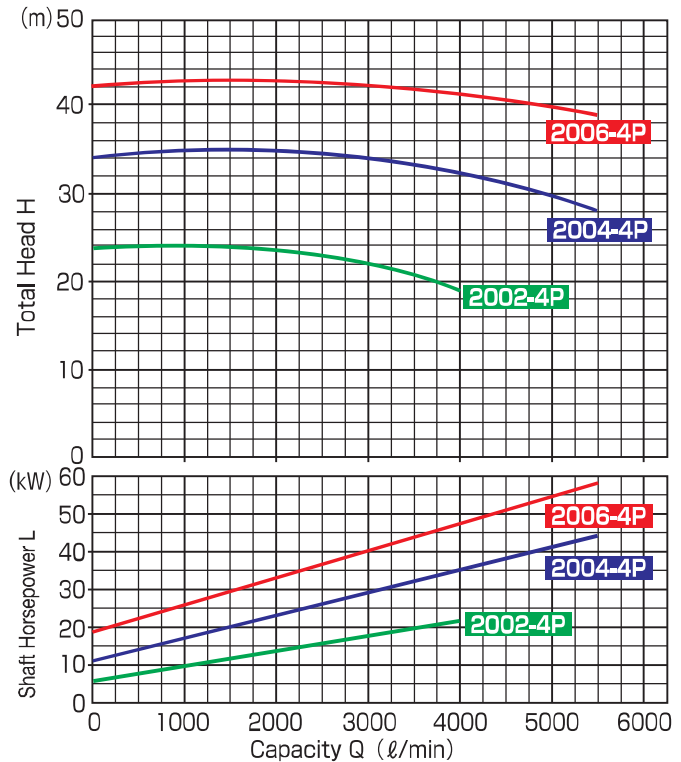

Model	Capacity (ℓ/min)	Total Head (m)	NPSH Re (m)	Motor Output (kW)
MTA-2002-4P	3600	20	4.0	11~55
MTA-2004-4P	4800	30	4.8	
MTA-2006-4P		40		

Note: NPSH Re values shown in the table are those obtained from the maximum suction pipe diameter.

Pump Identification

MTA-200 1 P 15 E A 4 Z
 ① ② ③ ④ ⑤ ⑥ ⑦ ⑧ ⑨

- ① Model
- ② Suction Pipe Size
- ③ Model Number Please refer to Performance Curve
- ④ Gasket Material P : PTFE (Jacketed)
Z : Other
- ⑤ Motor Output 15:11kW 20:15kW 25:18.5kW 30:22kW
40:30kW 50:37kW 60:45kW 75:55kW
- ⑥ Pump Body Material

Type	Casing	Impeller+Inner Magnet	Rear Casing
E		ETFE	C-PVDF

⑦ Parts Material Combination

Type	Shaft	Front & Rear Thrust Rings	Mouth Ring & Bearing
A	Alumina-ceramic		C-PTFE
B	SiC		
E(Standard)	SiC		C-PTFE
G	Alumina-ceramic		G-PTFE
H	SiC		G-PTFE
Z	Other Combinations or Special Option		

- ⑧ Number of Poles "4" is shown when a 4-pole motor is installed. ("6" is shown for 6-pole motors.)
- ⑨ Custom Specifications "Z" is shown when non-standard parts are used.

Dimensions

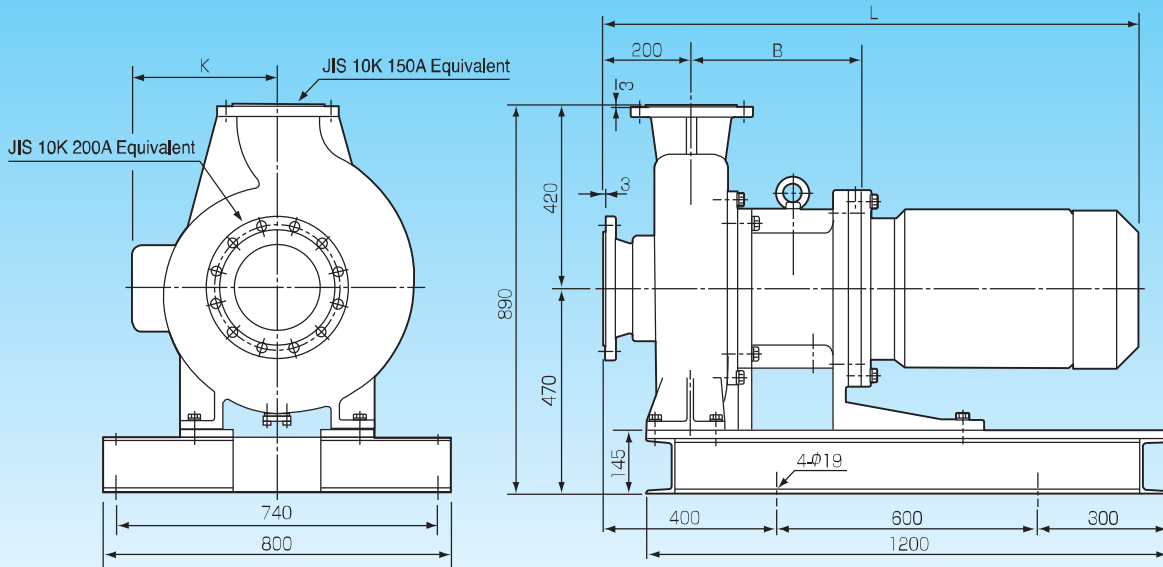

Motor Output (kW)	B	K	L	Weight (kg)
11 / 15	362	(265)	(1030)	(470)
18.5 / 22 / 30	362	(290)	(1060)	
37 / 45 / 55	392	(335)	(1230)	

- Note: ① The weight of pump does not include the motor weight.
 ② The dimensions shown above are applicable when a totally-enclosed fan-cooled motor is used.
 When using special motors (such as explosion-proof motors), please contact us.
 ③ The figures in parentheses are reference values.

Construction Diagram

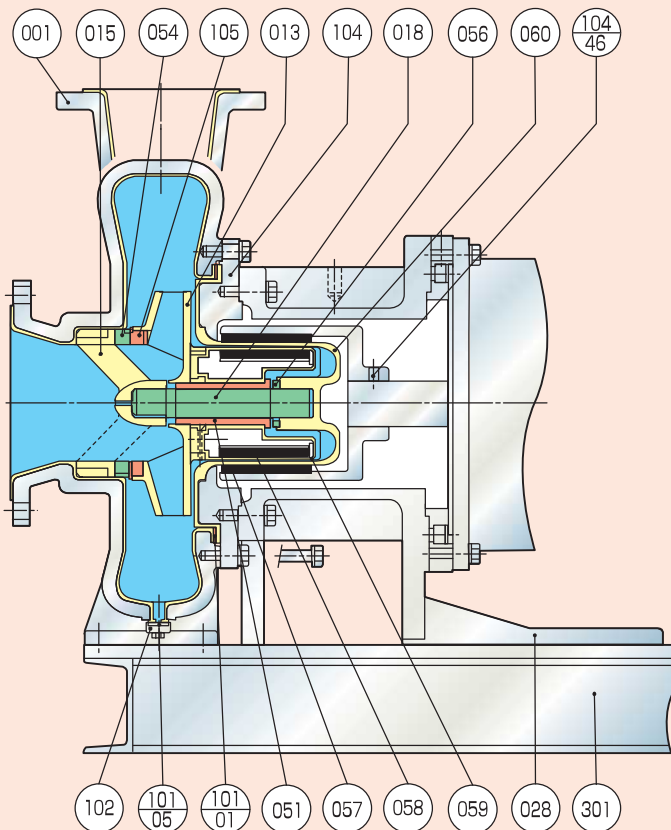

No.	Part Name	Materials
001	Casing	FCD450 + ETFE
013	Impeller	ETFE
015	Shaft Support	ETFE
018	Shaft	Alumina-ceramic / SiC
028	Bracket	FC200
051	Bearing	C-PTFE / SiC / G-PTFE
054	Front Thrust Ring	Alumina-ceramic / SiC
056	Rear Thrust Ring	Alumina-ceramic / SiC
057	Outer Magnet	Rare Earth
058	Inner Magnet	Rare Earth
059	Magnet Lining	ETFE
060	Rear Casing	C-PVDF
101-01	Casing Gasket	PTFE
101-05	Drain Gasket	PTFE (Jacketed)
102	Drain Flange	FC200
104	Rear Casing Plate	SS400
104-46	Outer Magnet Set Screw	SNCM
105	Mouth Ring	C-PTFE / SiC / G-PTFE
301	Base	SS400

Note: Inner Magnet (058) and Magnet Lining (059) are integrated and engaged with Impeller (013).

MSX-100 Series (Suction 100A × Discharge 80A)



Pump Specifications

- Operating Temperature -20~150°C (Please consult us about 0°C below and 100°C higher when used)
- Rotation Direction Clockwise (viewed from the motor)
- Flange JIS 10K RF (Please consult us about ANSI/DIN standard.)
- Finish Paint Munsell 2.5B4/8(pump body)
- Motor IEC flanged induction motor
- Accessories Base & Foundation bolts (M16×200L×63b)

50Hz Performance Curve & Technical Data

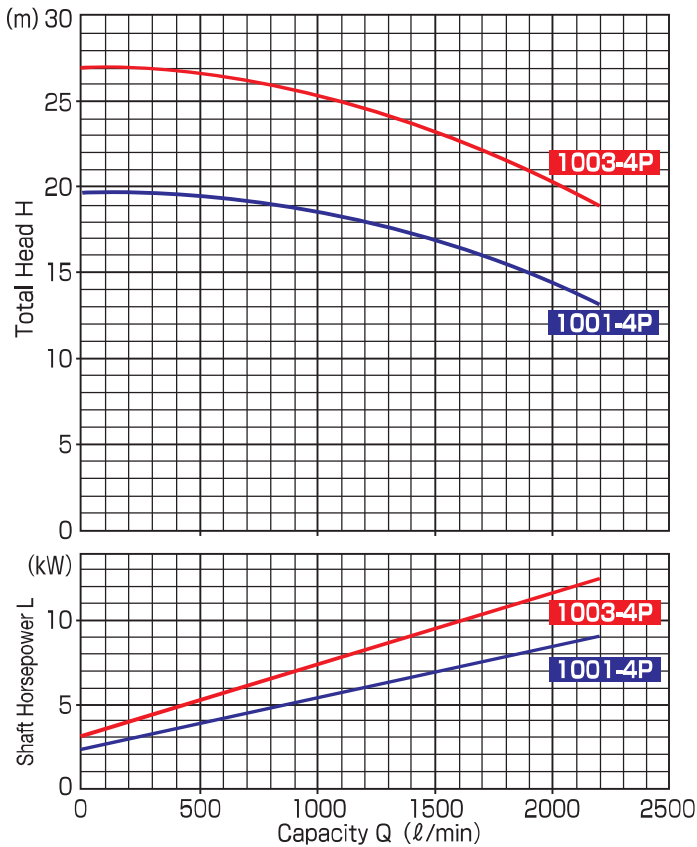

Model	Capacity (ℓ/min)	Total Head (m)	NPSH Re (m)	Motor Output (kW)
MSX-1001-4P	1500	15	3.0	5.5~18.5
MSX-1003-4P	2000	20	4.0	

Note: NPSH Re values shown in the table are those obtained from the maximum suction pipe diameter.

60Hz Performance Curve & Technical Data

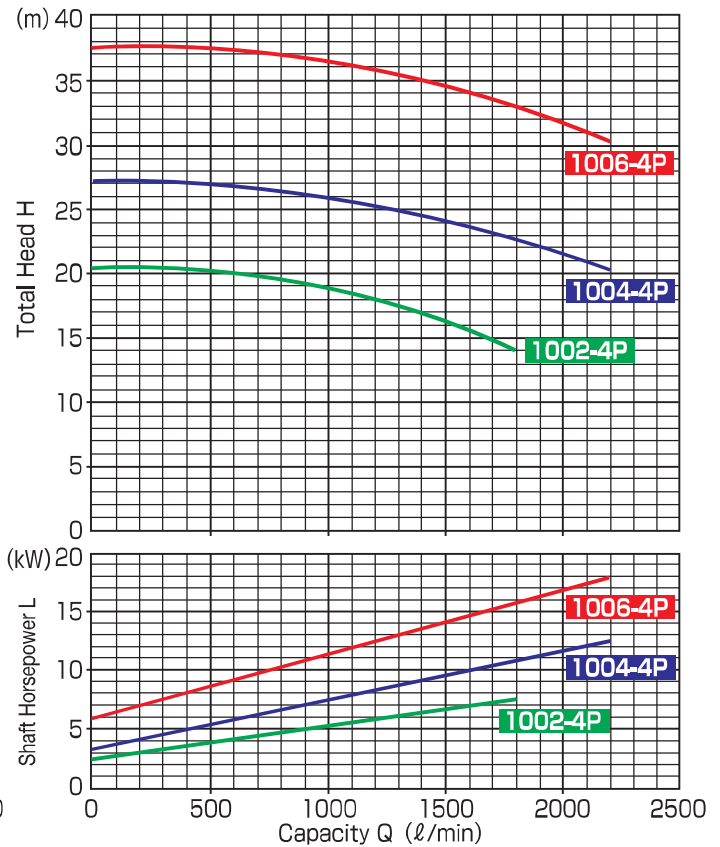

Model	Capacity (ℓ/min)	Total Head (m)	NPSH Re (m)	Motor Output (kW)
MSX-1002-4P	1500	15	3.5	5.5~22
MSX-1004-4P	2000	20	5.0	
MSX-1006-4P		30		

Note: NPSH Re values shown in the table are those obtained from the maximum suction pipe diameter.

Pump Identification

MSX-100 1 P 07 F A L

① ② ③ ④ ⑤ ⑥ ⑦ ⑧

- ① Model
- ② Suction Pipe Size
- ③ Model Number Please refer to Performance Curve
- ④ Gasket Material P : PTFE (Jacketed)
Z : Other
- ⑤ Motor Output 07 : 5.5kW 10 : 7.5kW 15 : 11kW
20 : 15kW 25 : 18.5kW 30 : 22kW(60Hz only)
- ⑥ Pump Body Material

Type	Casing	Impeller+Inner Magnet	Rear Casing
F		PFA	PFA+PEEK
S		PFA	SiC
Z	Other Combinations or Special Option		

- ⑦ Parts Material Combination

Type	Shaft	Front Thrust Ring	Mouth Ring	Bearing
A(Standard)		SiC		C-PTFE
B			SiC	
G		SiC		G-PTFE
Z	Other Combinations or Special Option			

- ⑧ Construction Identification

"L" is shown for long couplings only.

Dimensions

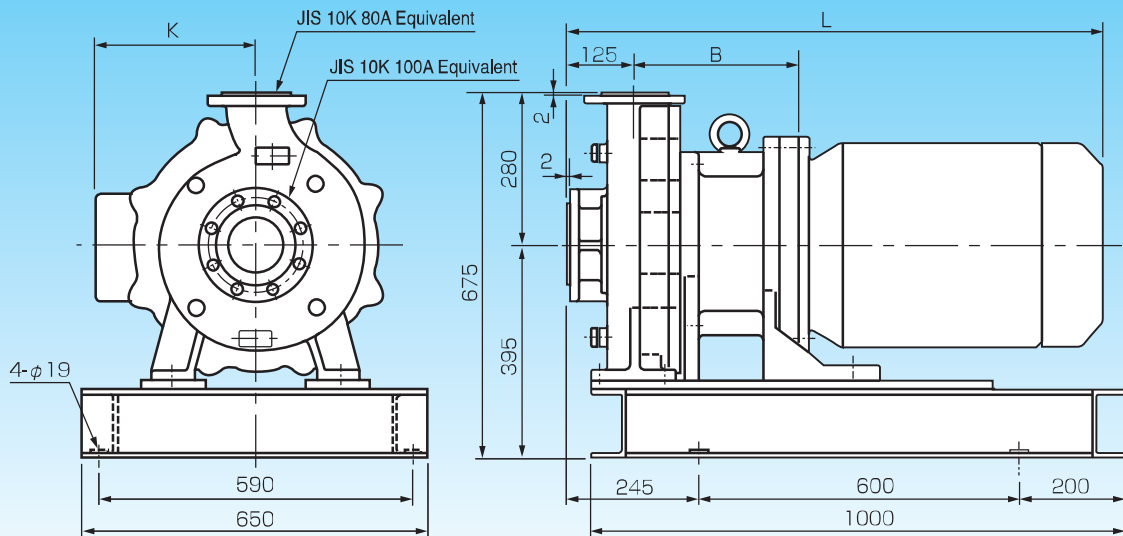

Motor Output (kW)	B	K	L	Weight (kg)
5.5 / 7.5	235	(300)	(1000)	(300)
11 / 15	308			
18.5				

Note: ① The weight of pump does not include the motor weight.
 ② The dimensions shown above are applicable when a totally-enclosed fan-cooled motor is used.
 When using special motors (such as explosion-proof motors), please contact us.
 ③ The figures in parentheses are reference values.

Construction Diagram

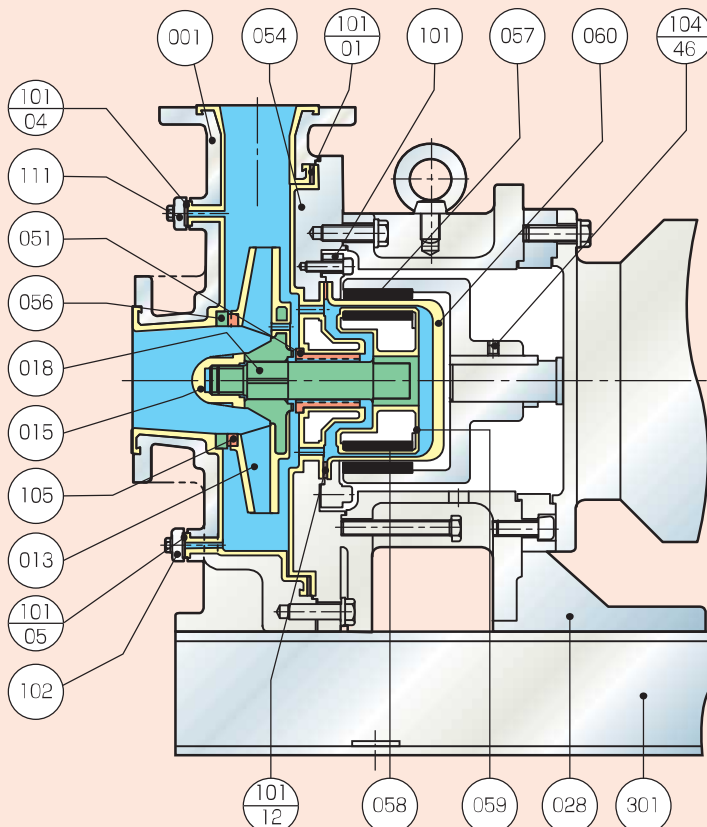

No.	Part Name	Materials
001	Casing	FCD450+PFA
013	Impeller	PFA+SiC
015	Impeller Nut	C-PTFE
018	Shaft	SiC
028	Bracket	FC200
051	Bearing	C-PTFE / SiC / G-PTFE
054	Bearing Plate	FCD450+PFA
056	Front Thrust Ring	SiC
057	Outer Magnet	Rare Earth
058	Inner Magnet	Rare Earth
059	Magnet Lining	PFA
060	Rear Casing	PFA(Wetted Parts) / SiC
101	Rear Casing Ring	SUS304
101-01	Casing Gasket	PTFE
101-04	Air Vent Gasket	PTFE(Jacketed)
101-05	Drain Gasket	PTFE(Jacketed)
101-12	Rear Casing Gasket	PTFE(Jacketed)
102	Drain Flange	FC200
104-46	Outer Magnet Set Screw	SNCM
105	Mouth Ring	C-PTFE / SiC / G-PTFE
111	Air Vent Flange	FC200
301	Base	SS400

Note: Inner Magnet (058) and Magnet Lining (059) are integrated.

MSX-125 Series (Suction 125A × Discharge 100A)



Pump Specifications

- Operating Temperature: -20~150°C (Please consult us about 0°C below and 100°C higher when used)
- Rotation Direction: Clockwise (viewed from the motor)
- Flange: JIS 10K RF (Please consult us about ANSI/DIN standard.)
- Finish Paint: Munsell 2.5B4/8 (pump body)
- Motor: IEC flanged induction motor
- Accessories: Base & Foundation bolts (M16×200L×63b)

50Hz Performance Curve & Technical Data

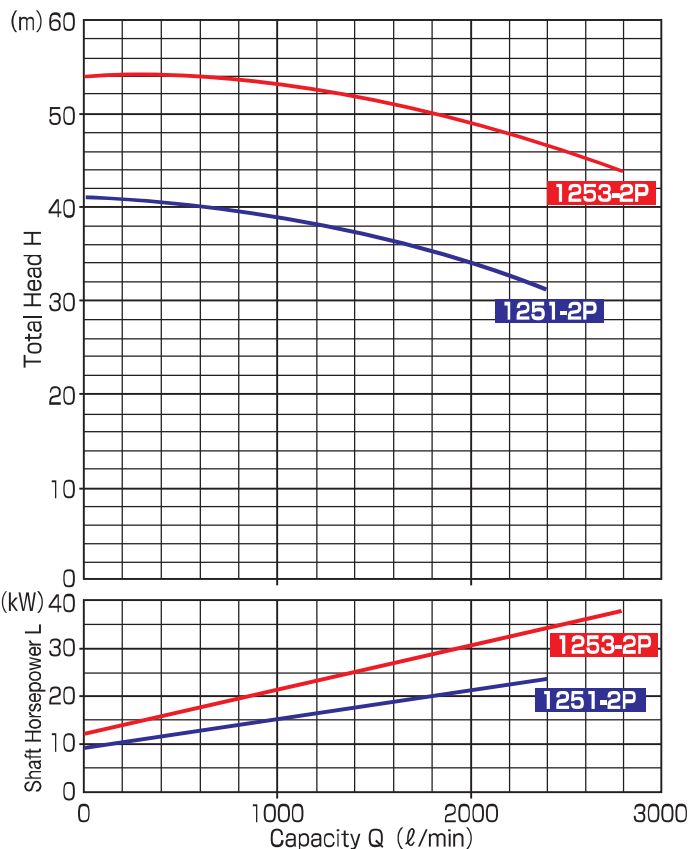

Model	Capacity (ℓ/min)	Total Head (m)	NPSH Re (m)	Motor Output (kW)
MSX-1251-2P	2000	30	5.0	11~30
MSX-1253-2P		40		

Note: NPSH Re value shown in the table is that obtained from the maximum suction pipe diameter.

60Hz Performance Curve & Technical Data

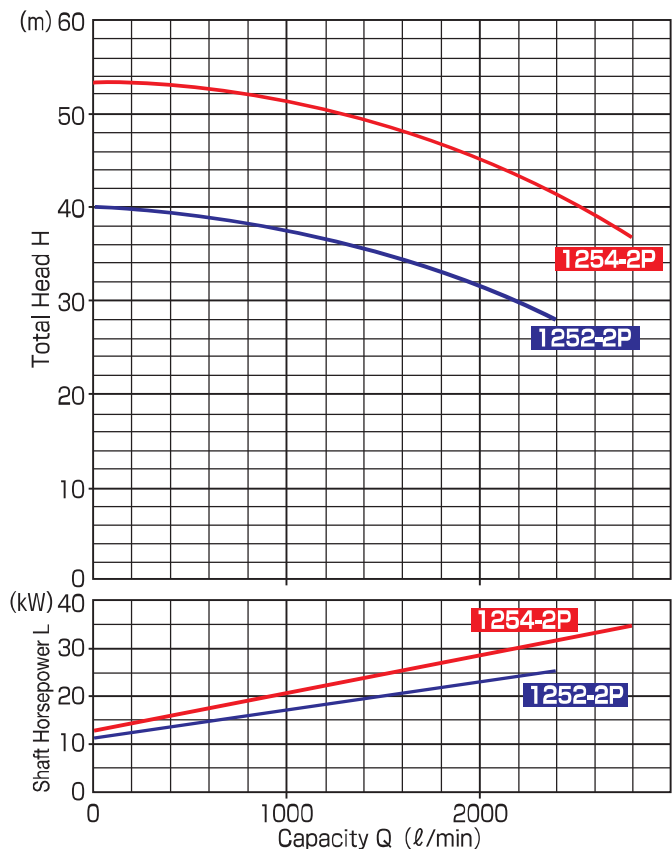

Model	Capacity (ℓ/min)	Total Head (m)	NPSH Re (m)	Motor Output (kW)
MSX-1252-2P	2000	30	6.5	11~37
MSX-1254-2P		40		

Note: NPSH Re value shown in the table is that obtained from the maximum suction pipe diameter.

Pump Identification

MSX-125 1 P 15 F A L

① ② ③ ④ ⑤ ⑥ ⑦ ⑧

- ① Model
- ② Suction Pipe Size
- ③ Model Number: Please refer to Performance Curve
- ④ Gasket Material: P : PTFE (Jacketed), Z : Other
- ⑤ Motor Output: 15 : 11kW, 20 : 15kW, 25 : 18.5kW, 30 : 22kW, 40 : 30kW, 50 : 37kW
- ⑥ Pump Body Material

Type	Casing	Impeller+Inner Magnet	Rear Casing
F		PFA	PFA+PEEK
S		PFA	SiC
Z	Other Combinations or Special Option		

- ⑦ Parts Material Combination

Type	Shaft	Front Thrust Ring	Mouth Ring	Bearing
A(Standard)	SiC		C-PTFE	
B	SiC			
G	SiC		G-PTFE	
Z	Other Combinations or Special Option			

- ⑧ Construction Identification: "L" is shown for long couplings only.

Dimensions

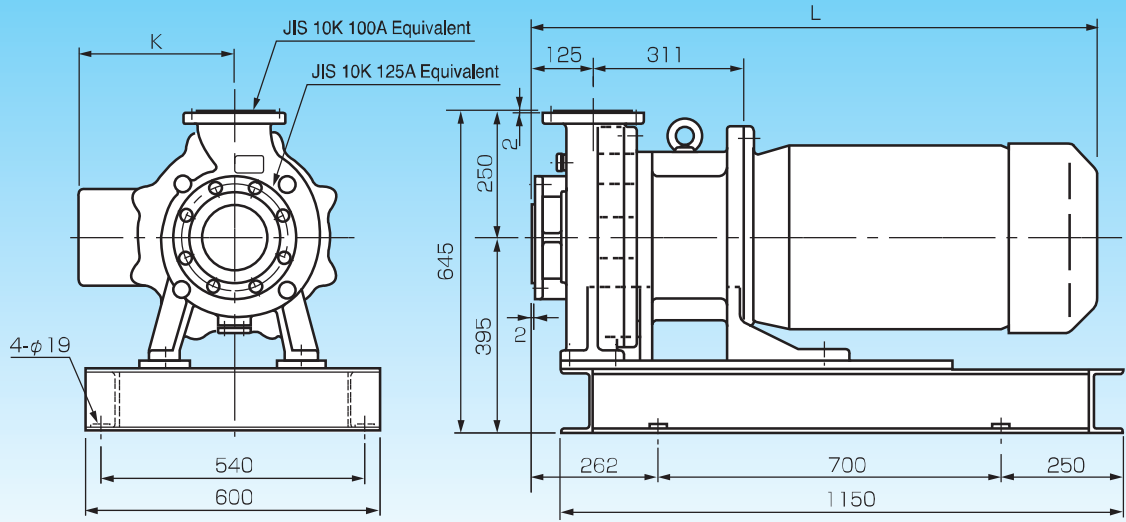

Motor Output (kW)	K	L	Weight (kg)
11~37	(330)	(1200)	(300)

- Note: ① The weight of pump does not include the motor weight.
 ② The dimensions shown above are applicable when a totally-enclosed fan-cooled motor is used.
 When using special motors (such as explosion-proof motors), please contact us.
 ③ The figures in parentheses are reference values.

Construction Diagram

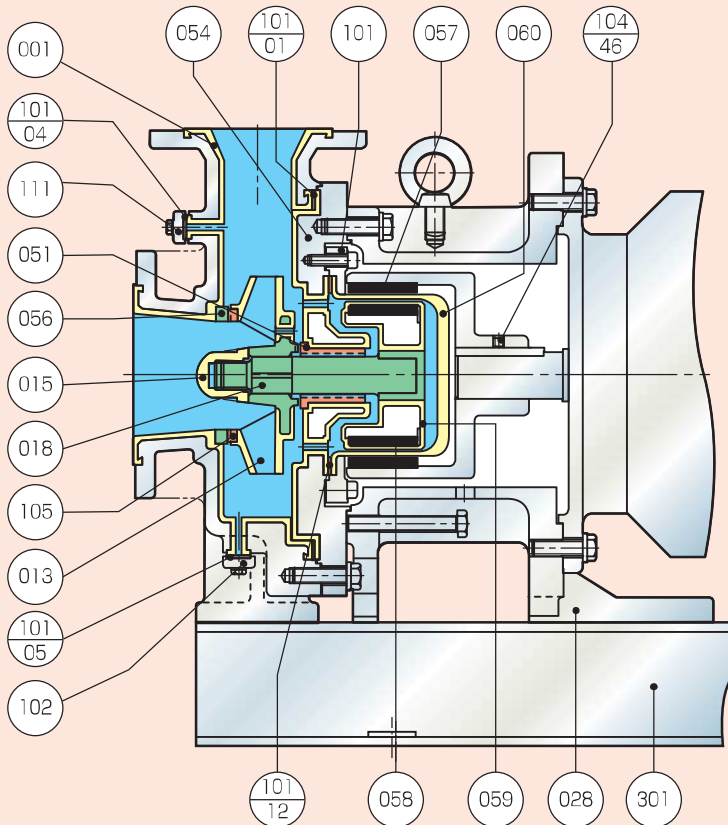

No.	Part Name	Materials
001	Casing	FCD450+PFA
013	Impeller	PFA+SiC
015	Impeller Nut	C-PTFE
018	Shaft	SiC
028	Bracket	FC200
051	Bearing	C-PTFE / SiC / G-PTFE
054	Bearing Plate	FCD450+PFA
056	Front Thrust Ring	SiC
057	Outer Magnet	Rare Earth
058	Inner Magnet	Rare Earth
059	Magnet Lining	PFA
060	Rear Casing	PFA(Wetted Parts) / SiC
101	Rear Casing Ring	SUS304
101-01	Casing Gasket	PTFE
101-04	Air Vent Gasket	PTFE(Jacketed)
101-05	Drain Gasket	PTFE(Jacketed)
101-12	Rear Casing Gasket	PTFE(Jacketed)
102	Drain Flange	FC200
104-46	Outer Magnet Set Screw	SNCM
105	Mouth Ring	C-PTFE / SiC / G-PTFE
111	Air Vent Flange	FC200
301	Base	SS400

Note: Inner Magnet (058) and Magnet Lining (059) are integrated.

MSX-150 Series (Suction 150A×Discharge 125A)



Pump Specifications

- Operating Temperature 0~90°C
- Rotation Direction Clockwise (viewed from the motor)
- Flange JIS 10K RF (Please consult us about ANSI/DIN standard.)
- Finish Paint Munsell 2.5B4/8(pump body)
- Motor IEC flanged induction motor
- Accessories Base & Foundation bolts (M16×200L×63b)

50Hz Performance Curve & Technical Data

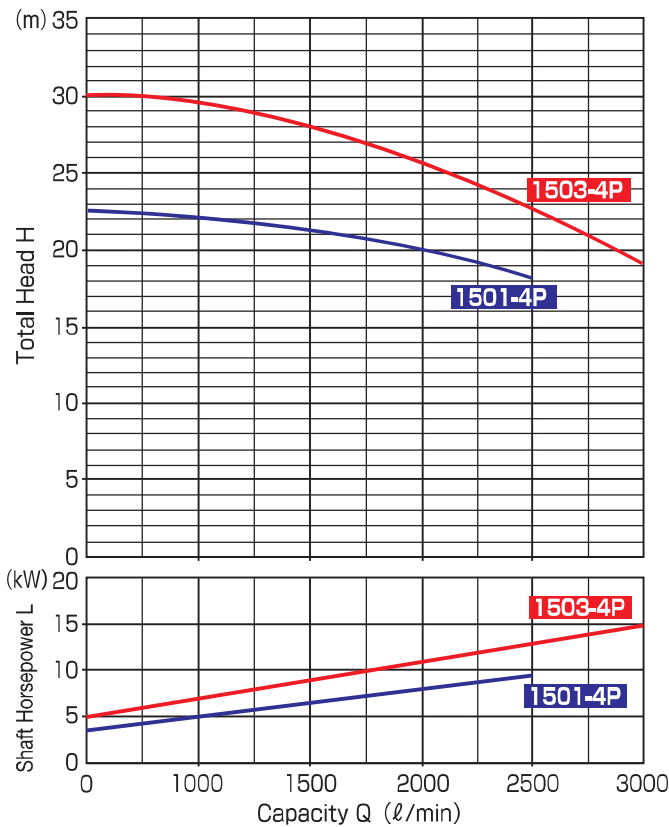

60Hz Performance Curve & Technical Data

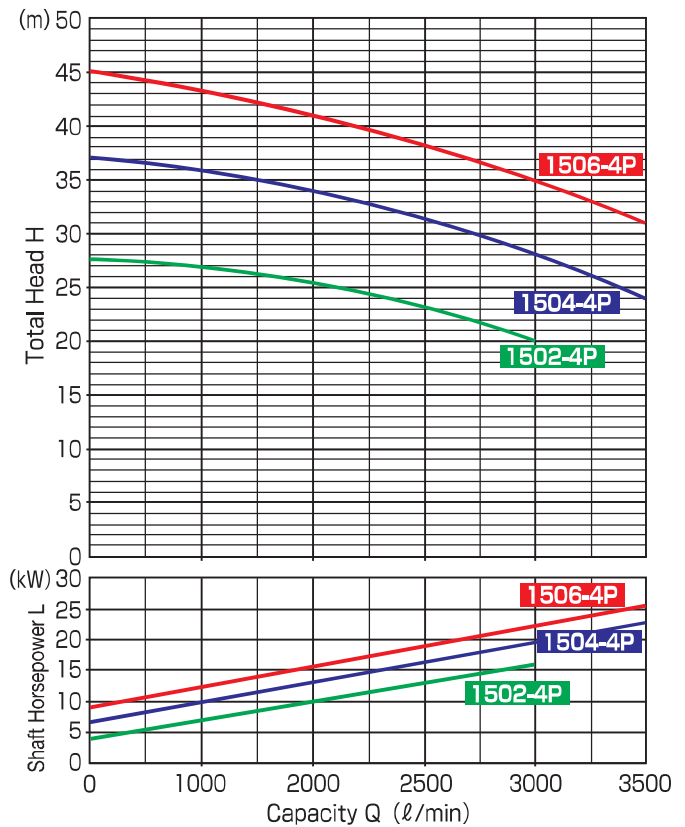

Model	Capacity (l/min)	Total Head (m)	NPSH Re (m)	Motor Output (kW)
MSX-1501-4P	2000	20	2.5	11~30
MSX-1503-4P		22		

Note: NPSH Re value shown in the table is that obtained from the maximum suction pipe diameter.

Model	Capacity (l/min)	Total Head (m)	NPSH Re (m)	Motor Output (kW)
MSX-1502-4P	2500	20	3.8	11~30
MSX-1504-4P		30		
MSX-1506-4P	3000	33	4.4	

Note: NPSH Re values shown in the table are those obtained from the maximum suction pipe diameter.

Pump Identification

MSX-150 1 P 15 F A L
 ① ② ③ ④ ⑤ ⑥ ⑦ ⑧

- ① Model
- ② Suction Pipe Size
- ③ Model Number Please refer to Performance Curve
- ④ Gasket Material P : PTFE (Jacketed) Z : Other
- ⑤ Motor Output 15 : 11kW 20 : 15kW 25 : 18.5kW
30 : 22kW 40 : 30kW
- ⑥ Pump Body Material

Type	Casing	Impeller	Inner Magnet	Rear Casing
F	ETFE	PVDF	PFA	PFA+PEEK
S	ETFE	PVDF	PFA	SiC
Z	Other Combinations or Special Option			

- ⑦ Parts Material Combination

Type	Shaft	Front Thrust Ring	Mouth Ring	Bearing
A(Standard)	SiC		C-PTFE	
B	SiC			
G	SiC		G-PTFE	
Z	Other Combinations or Special Option			

- ⑧ Construction Identification

"L" is shown for long couplings only.

MSX Series

Dimensions

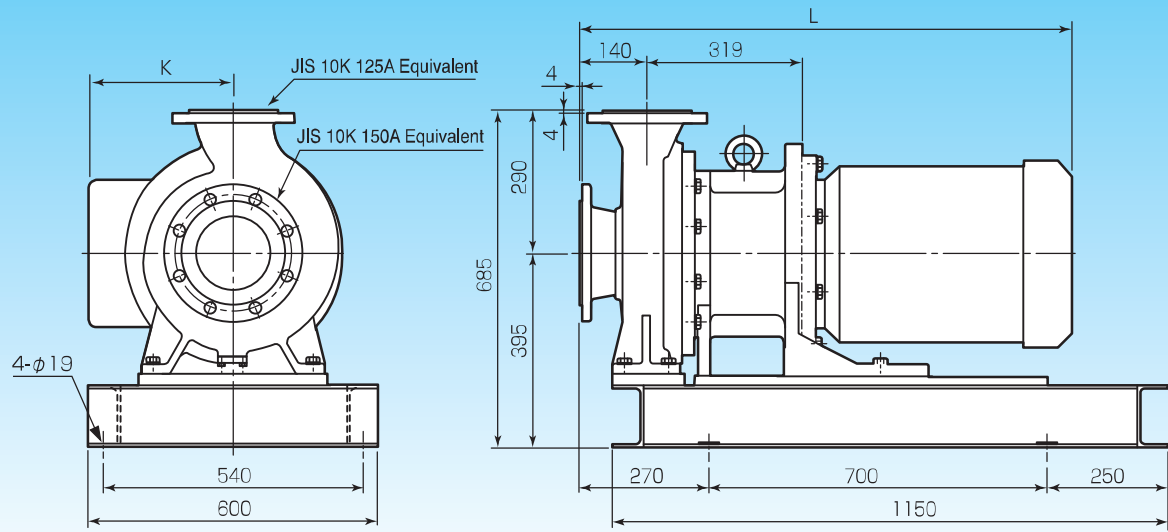

Motor Output (kW)	K	L	Weight (kg)
11~30	(350)	(1020)	(350)

Note: ① The weight of pump does not include the motor weight.
 ② The dimensions shown above are applicable when a totally-enclosed fan-cooled motor is used.
 When using special motors (such as explosion-proof motors), please contact us.
 ③ The figures in parentheses are reference values.

Construction Diagram

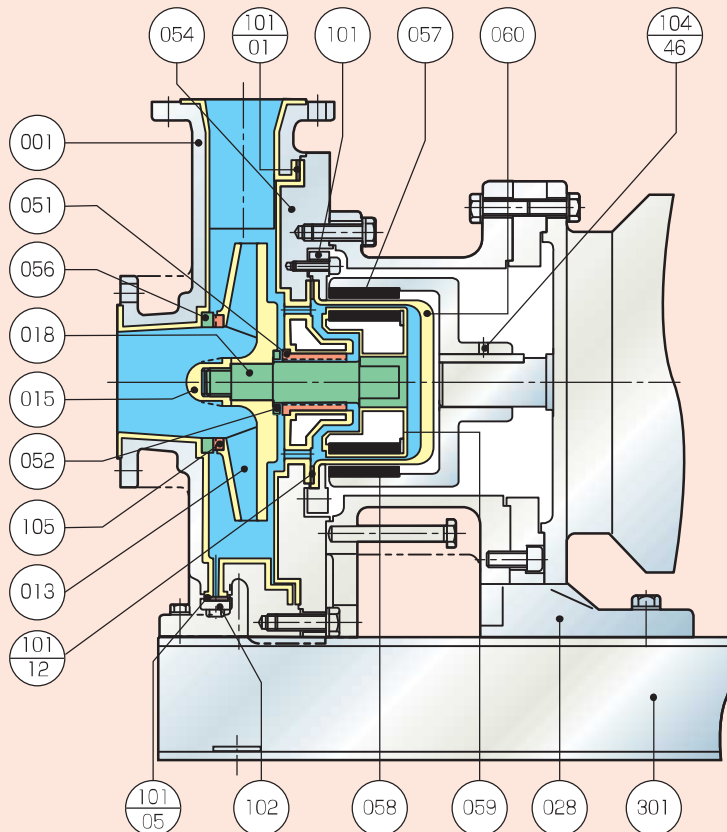

No.	Part Name	Materials
001	Casing	FCD450+ETFE
013	Impeller	PVDF
015	Impeller Nut	C-PTFE
018	Shaft	SiC
028	Bracket	FC200
051	Bearing	C-PTFE / SiC / G-PTFE
052	Rear Thrust Ring	SiC
054	Bearing Plate	FCD450+PFA
056	Front Thrust Ring	SiC
057	Outer Magnet	Rare Earth
058	Inner Magnet	Rare Earth
059	Magnet Lining	PFA
060	Rear Casing	PFA (Wetted Parts) / SiC
101	Rear Casing Ring	SUS304
101-01	Casing Gasket	PTFE
101-05	Drain Gasket	PTFE(Jacketed)
101-12	Rear Casing Gasket	PTFE(Jacketed)
102	Drain Flange	FC200
104-46	Outer Magnet Set Screw	SNCM
105	Mouth Ring	C-PTFE / SiC / G-PTFE
301	Base	SS400

Note: Inner Magnet (058) and Magnet Lining (059) are integrated.

MST-050 Series (Suction 50A × Discharge 40A)



Pump Specifications

- Operating Temperature -20~150°C (Please consult us about 0°C below when used)
- Rotation Direction Clockwise (viewed from the motor)
- Flange JIS 10K RF (M16 Tapped hole) (Please consult us about ANSI/DIN standard.)
- Finish Paint Munsell 2.5B4/8(pump body)
- Motor IEC flanged induction motor
- Accessories Base & Foundation bolts (M12×160L×50b)

50Hz Performance Curve & Technical Data

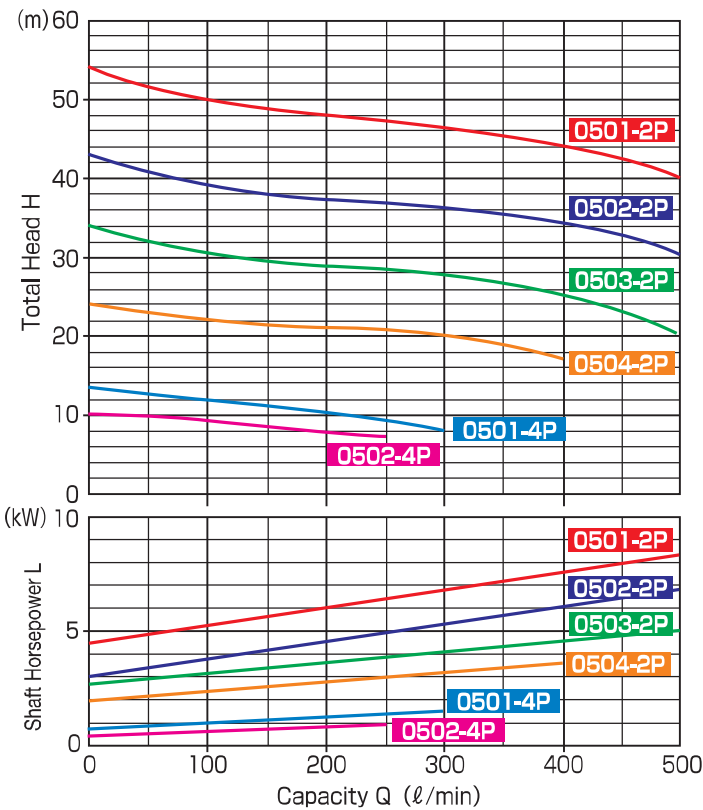

Model	Capacity (ℓ/min)	Total Head (m)	NPSH Re (m)	Motor Output (kW)
MST-0501-2P	300	46	4.5	3.7~18.5
MST-0502-2P		36		
MST-0503-2P		27		
MST-0504-2P		20		
MST-0501-4P	150	10	2.0	2.2~5.5
MST-0502-4P		8		

Note: NPSH Re values shown in the table are those obtained from the maximum suction pipe diameter.

60Hz Performance Curve & Technical Data

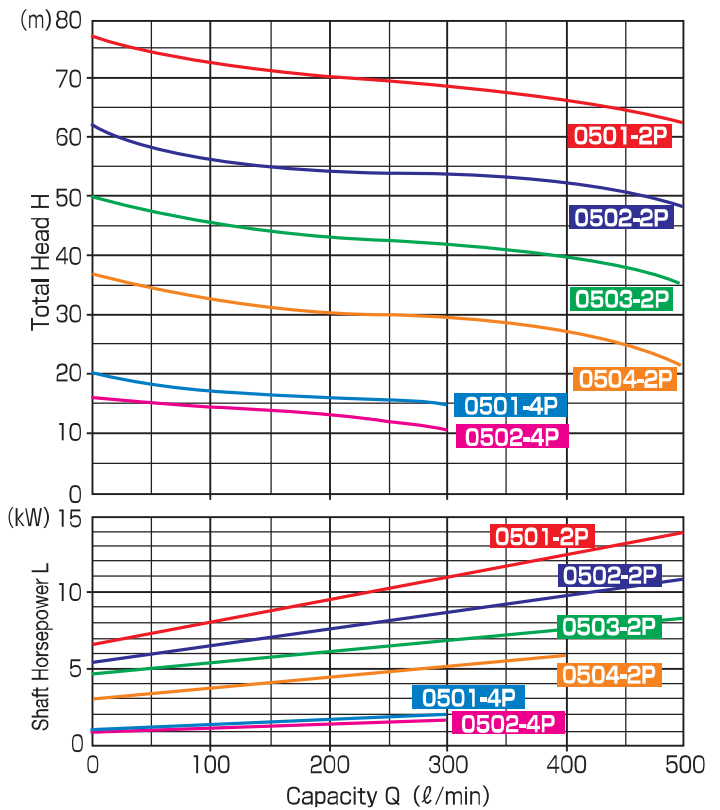

Model	Capacity (ℓ/min)	Total Head (m)	NPSH Re (m)	Motor Output (kW)
MST-0501-2P	300	67	5.5	3.7~22
MST-0502-2P		53		
MST-0503-2P		42		
MST-0504-2P		28		
MST-0501-4P	150	16	2.5	2.2~5.5
MST-0502-4P		13		

Note: NPSH Re values shown in the table are those obtained from the maximum suction pipe diameter.

Pump Identification

MST-050 1 P 03 S 2 F 1
 ① ② ③ ④ ⑤ ⑥ ⑦ ⑧ ⑨

- ① Model ② Suction Pipe Size
- ③ Model Number Please refer to Performance Curve
- ④ Gasket Material P : PTFE (Jacketed)
Z : Other
- ⑤ Motor Output 03 : 2.2kW 05 : 3.7kW 07 : 5.5kW
10 : 7.5kW 15 : 11kW 20 : 15kW
25 : 18.5kW 30 : 22kW (60Hz only)

⑥ Parts Material Combination

Type	Shaft	Thrust Ring	Bushing
G	SiC	G-PTFE	
S	SiC		
T(Standard)	SiC	C-PTFE	
Z	Other Combinations or Special Option		

- ⑦ Number of Poles 2 : 2P 4 : 4P
- ⑧ Motor Type F : Flanged Induction Motor
- ⑨ Motor Frequency 1 : 50Hz 2 : 60Hz

Dimensions

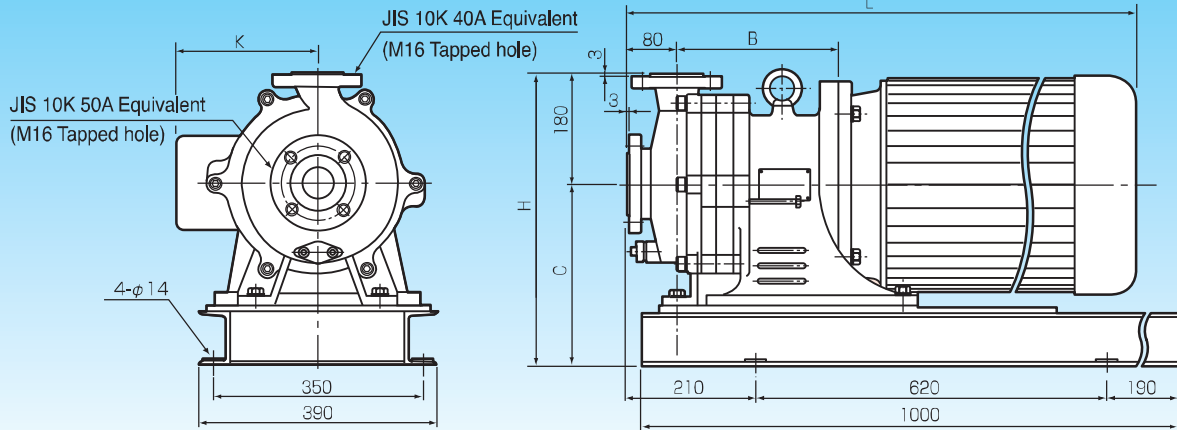

Motor Output (kW)	B	C	H	K	L	Weight (kg)
3,7	281	296	476	(285)	(900)	(185)
5,5/7,5	301					
11/15/18,5	331	326	506			
22						

- Note: ① The weight of pump does not include the motor weight.
 ② The dimensions shown above are applicable when a totally-enclosed fan-cooled 2-pole motor is used. When using special motors (such as explosion-proof motors), please contact us.
 ③ The figures in parentheses are reference values.

Construction Diagram

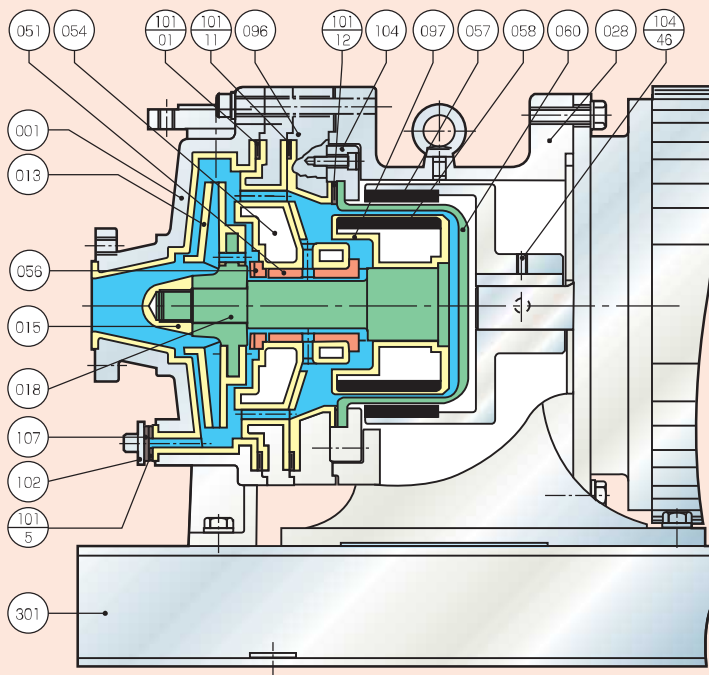

No.	Part Name	Materials
001	Casing	FCD450+PFA
013	Impeller	PFA+SiC
015	Impeller Nut	C-PTFE
018	Shaft	SiC
028	Bracket	SS400 / FC250
051	Bushing	C-PTFE / SiC / G-PTFE
054	Bushing Plate	PFA+FCD450
056	Thrust Ring	C-PTFE / SiC / G-PTFE
057	Outer Magnet	Rare Earth
058	Inner Magnet	Rare Earth
060	Rear Casing	SiC
096	Spacer Plate	FCD450+PFA
097	Magnet Capsule	PFA
107	Gasket Plate	C-PTFE / PTFE
101-01	Casing Gasket	PTFE(Jacketed)
101-05	Drain Gasket	PTFE(Jacketed)
101-11	Bushing Plate Gasket	PTFE(Jacketed)
101-12	Rear Casing Gasket	PTFE(Jacketed)
102	Drain Flange	FC250
104	Rear Casing Plate	SUS304
104-46	Outer Magnet Set Screw	SNCM
301	Base	SS400

Note: Inner Magnet (058) and Magnet Capsule (097) are integrated.

MES-040 Series (Suction 40A×Discharge 40A)



Pump Specifications

- Operating Temperature 0~80℃
- Rotation Direction Clockwise (viewed from the motor)
- Flange JIS 10K FF (Please consult us about ANSI/DIN standard,)
- Finish Paint Munsell 2,5B4/8(pump body)
- Motor IEC flanged induction motor
- Accessories Base & Foundation bolts (M12×160L×50b)

50Hz Performance Curve & Technical Data

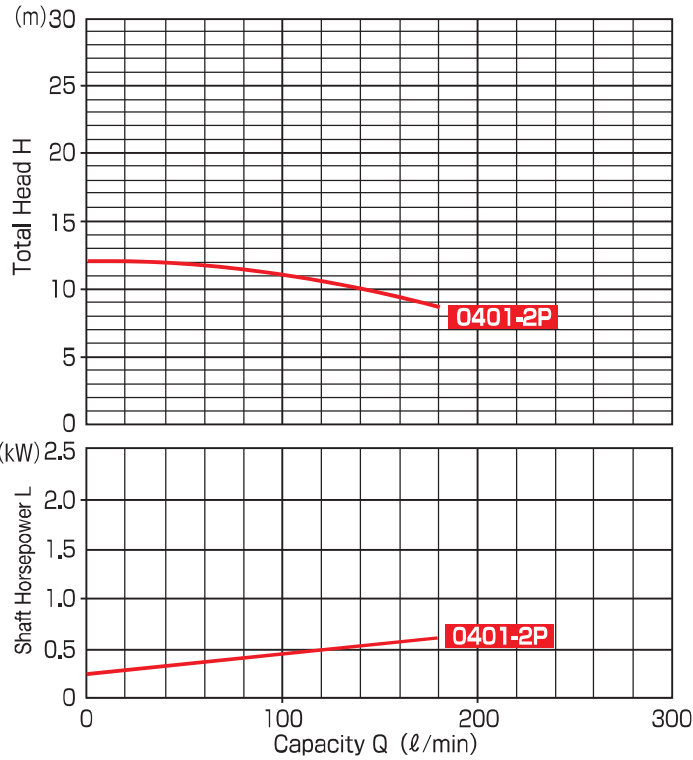

60Hz Performance Curve & Technical Data

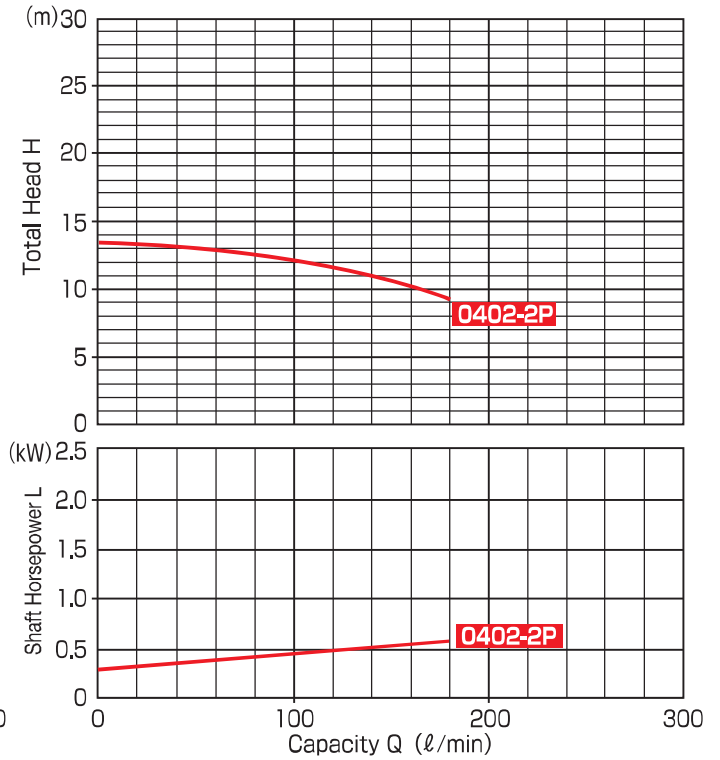

Model	Capacity (ℓ/min)	Total Head (m)	NPSH Re (m)	Motor Output (kW)
MES-0401-2P	100	10	2.2	0.75

Note: NPSH Re value shown in the table is that obtained from the maximum suction pipe diameter.

Model	Capacity (ℓ/min)	Total Head (m)	NPSH Re (m)	Motor Output (kW)
MES-0402-2P	100	12	2.6	0.75

Note: NPSH Re value shown in the table is that obtained from the maximum suction pipe diameter.

Pump Identification

MES-040 1 F 01 A C F
 ① ② ③ ④ ⑤ ⑥ ⑦ ⑧

- ① Model
- ② Suction Pipe Size
- ③ Model Number Please refer to Performance Curve
- ④ O-ring Material
F : FPM E : EPDM
- ⑤ Motor Output 01 : 0.75kW
- ⑥ Pump Body Material

- ⑦ Motor Type
C: Totally-enclosed fan-cooled type, explosion-proof increased safety type
T: Pressure-resistant explosion-proof type

⑧ Parts Material Combination

Type	Shaft	Front Thrust Ring	Rear Thrust Ring	Mouth Ring	Bearing
A	Alumina-ceramic			C-PTFE	
F(Standard)	Alumina-ceramic			Carbon	
Z	Other Combinations or Special Option				

Type	Tank	Casing	Impeller + Inner Magnet	Rear Casing
A	G-PP	G-PP	G-PP + PP	G-PP

Dimensions

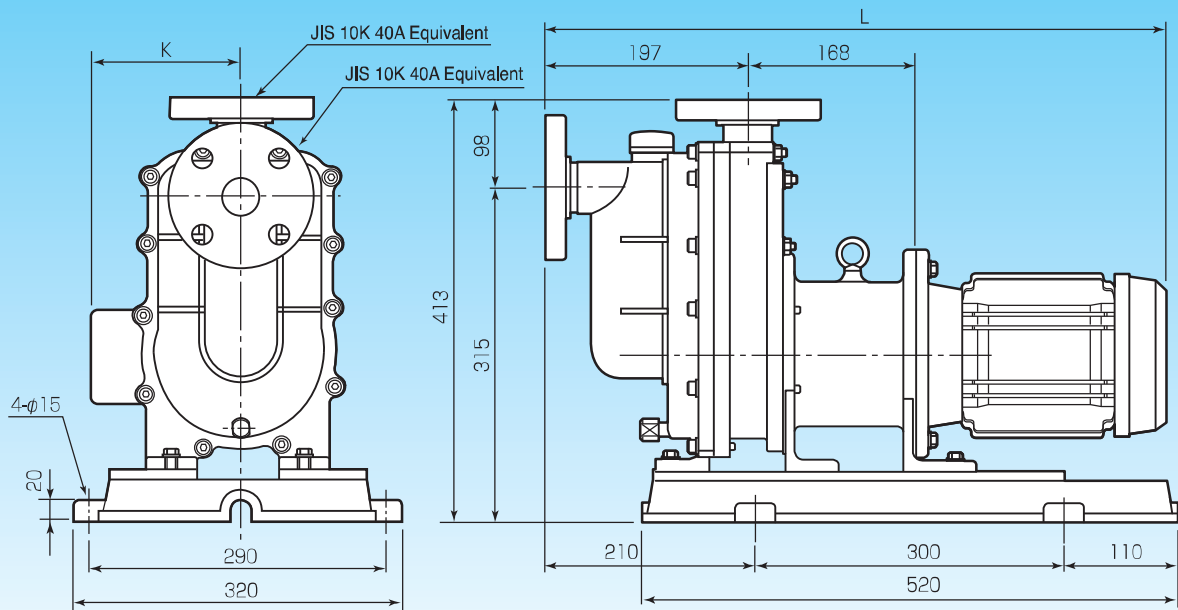

Motor Output	K	L	Weight (kg)
0.75kW	(120)	(610)	(34)

Note : ① The weight of pump does not include the motor weight.
 ② The figures in parentheses are reference values.

Construction Diagram

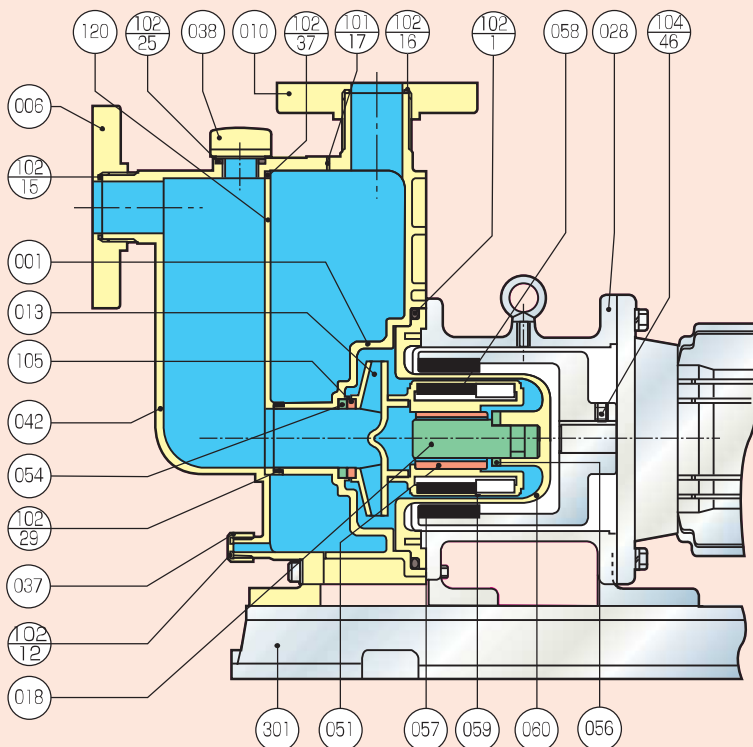

No.	Part Name	Materials
001	Casing	G-PP
006	Suction Flange	G-PP
010	Discharge Flange	G-PP
013	Impeller	G-PP
018	Shaft	Alumina-ceramic
028	Bracket	FC200
037	Drain Plug	G-PP
038	Air Vent Plug	G-PP
042	Tank	G-PP
051	Bearing	Carbon/C-PTFE
054	Front Thrust Ring	Alumina-ceramic
056	Rear Thrust Ring	Alumina-ceramic
057	Outer Magnet	Ferrite
058	Inner Magnet	Ferrite
059	Magnet Lining	PP
060	Rear Casing	G-PP
101-17	Tank Gasket	FPM / EPDM
102-01	O-ring(Casing)	FPM / EPDM
102-12	O-ring(Drain Plug)	FPM / EPDM
102-15	O-ring(Suction Flange)	FPM / EPDM
102-16	O-ring(Discharge Flange)	FPM / EPDM
102-25	O-ring(Air Vent Plug)	FPM / EPDM
102-29	O-ring(Suction)	FPM / EPDM
102-37	Partition Plate Gasket	FPM / EPDM
105	Mouth Ring	Carbon/C-PTFE
104-46	Outer Magnet Set Screw	SNCM
120	Partition Plate	G-PP
301	Base	FC200

Note: Inner Magnet (058) and Magnet Lining (059) are integrated and engaged with Impeller (013).



Pump Specifications

- Operating Temperature 0~80℃
- Rotation Direction Clockwise (viewed from the motor)
- Flange JIS 10K FF (Please consult us about ANSI/DIN standard.)
- Finish Paint Munsell 2,5B4/8(pump body)
- Motor TEXEL flanged induction motor / IEC flanged induction motor
- Accessories Base & Foundation bolts (M12×160L×50b)

50Hz Performance Curve & Technical Data

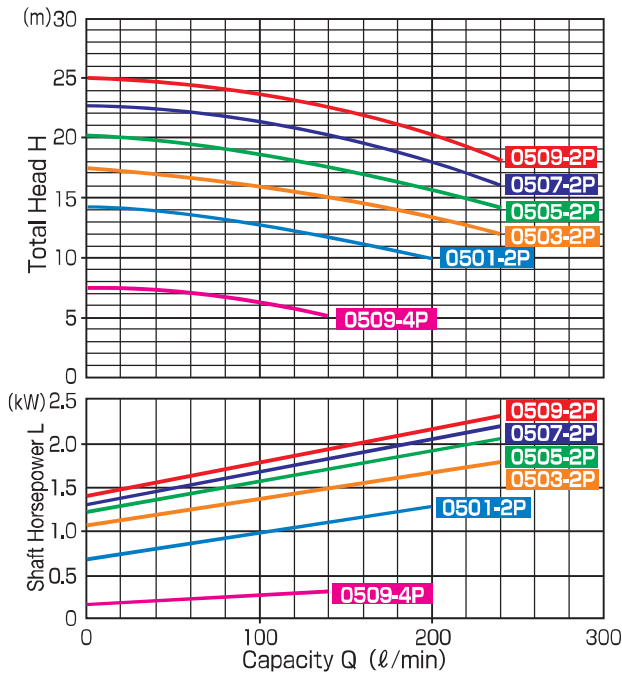

60Hz Performance Curve & Technical Data

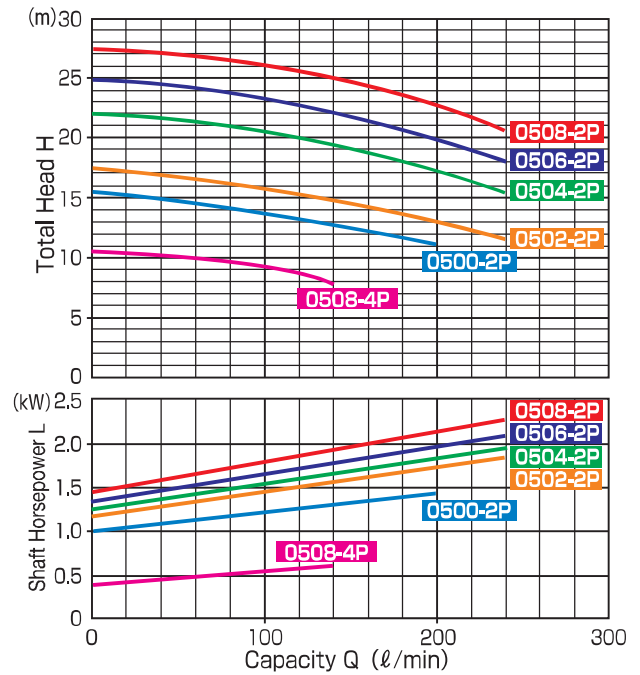

Model	Capacity (ℓ/min)	Total Head (m)	NPSH Re (m)	Motor Output (kW)
MES-0501-2P	200	10	1.8	0.75~3.7
MES-0503-2P		13		
MES-0505-2P		15		
MES-0507-2P		18		
MES-0509-2P		20		
MES-0509-4P	100	6	1.0	0.4 · 0.75

Model	Capacity (ℓ/min)	Total Head (m)	NPSH Re (m)	Motor Output (kW)
MES-0500-2P	200	10	2.5	0.75~3.7
MES-0502-2P		13		
MES-0504-2P		15		
MES-0506-2P		18		
MES-0508-2P		20		
MES-0508-4P	100	9	1.5	0.75

Note: ① Motor output of 0.4 kW (4-pole) is only applicable when a TEXEL flanged induction motor is used.
 ② Motor output of 3.7 kW is only applicable when an IEC flanged induction motor is used.
 ③ NPSH Re values shown in the table are those obtained from the maximum suction pipe diameter.

Note: ① Motor output of 3.7 kW is only applicable when an IEC flanged induction motor is used.
 ② NPSH Re values shown in the table are those obtained from the maximum suction pipe diameter.

Pump Identification

MES - 050 1 F 01 A S F 4
 ① ② ③④ ⑤ ⑥ ⑦⑧ ⑨

- ① Model
- ② Suction Pipe Size
- ③ Model Number Please refer to Performance Curve
- ④ O-ring Material
F : FPM E : EPDM Z : Other
- ⑤ Motor Output
00 : 0.4kW 01 : 0.75kW 02 : 1.5kW
03 : 2.2kW 05 : 3.7kW
- ⑥ Pump Body Material

Type	Tank	Casing	Impeller	Inner Magnet	Rear Casing
A	PP				C-PVDF
P	PVDF				
Z	Other Combinations or Special Option				

⑦ Motor Type

S: TEFC/outdoor TEXEL motor A: Explosion-proof increased safety (eG3) TEXEL motor
 T: IEC standard explosion-proof (d2G4) motor C : Other

⑧ Material Combination

Type	Shaft	Front Thrust Ring	Rear Thrust Ring	Mouth Ring	Bearing
A	Alumina-ceramic			C-PTFE	
B	SiC				
C	SiC			Carbon	
E	SiC			C-PTFE	
F(Standard)	Alumina-ceramic			Carbon	
G	Alumina-ceramic			G-PTFE	
Z	Other Combinations or Special Option				

⑨ Number of Poles "4" is shown only when a 4-pole motor is installed.

Dimensions

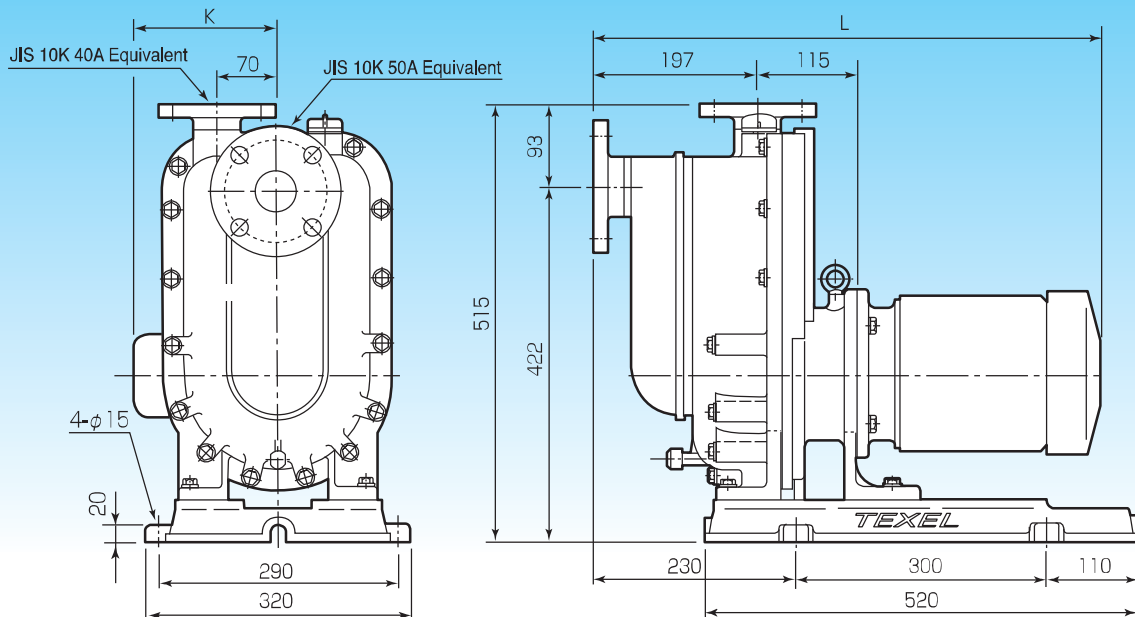

Motor Output (kW)	TEFC		eG3		Weight (kg)
	K	L	K	L	
0.4	147	541	150	550	(41)
0.75	161	559	169	559	
1.5	176	585	183	585	
2.2	176	605	205	616	

- Note: ① The weight of pump does not include the motor weight.
 ② The dimensions shown above are applicable when a TEXEL flanged induction motor (2-pole) is used.
 When using special motors (such as explosion-proof motors), please contact us.
 ③ The figures in parentheses are reference values.
 ④ Please consult us when you use 3.7kW IEC flanged motor.

Construction Diagram

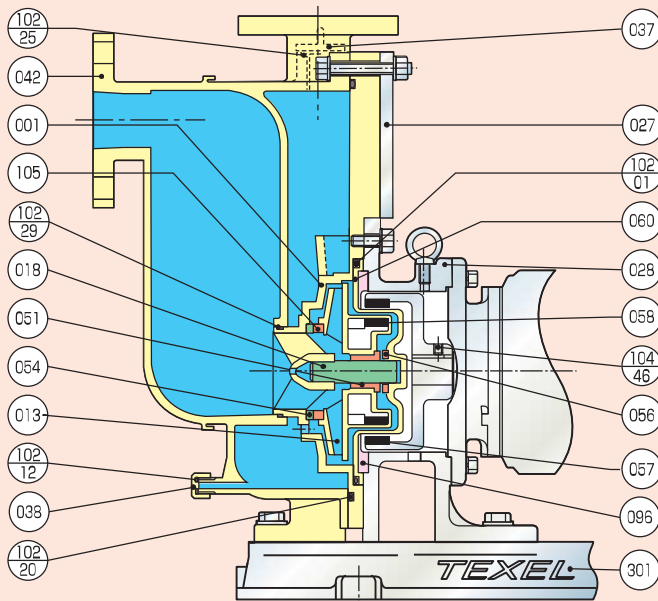

No.	Part Name	Materials
001	Casing	PP / PVDF
013	Impeller	PP / PVDF
018	Shaft	Alumina-ceramic/SiC
027	Casing Support	FC200
028	Bracket	FC200
037	Air Vent Plug	PP / PVDF
038	Drain Plug	PP / PVDF
042	Tank	PP / PVDF
051	Bearing	C-PTFE / SiC / Carbon / G-PTFE
054	Front Thrust Ring	Alumina-ceramic / SiC
056	Rear Thrust Ring	Alumina-ceramic / SiC
057	Outer Magnet	Rare Earth
058	Inner Magnet	Rare Earth
060	Rear Casing	C-PVDF
096	Bracket Ring	SS400
102-01	O-ring(Casing)	FPM / EPDM
102-12	O-ring(Drain Plug)	FPM / EPDM
102-20	O-ring(Tank)	FPM / EPDM
102-25	O-ring(Air Vent Plug)	FPM / EPDM
102-29	O-ring(Suction)	FPM / EPDM
104-46	Outer Magnet Set Screw	SNCM
105	Mouth Ring	C-PTFE / SiC / Carbon / G-PTFE
301	Base	FC200

Note: Inner Magnet (058) and Impeller (013) are integrated.

MES-080 Series (Suction 80A × Discharge 80A)



Pump Specifications

- Operating Temperature 0~80℃
- Rotation Direction Clockwise (viewed from the motor)
- Flange JIS 10K FF (Please consult us about ANSI/DIN standard.)
- Finish Paint Munsell 2.5B4/8(pump body)
- Motor TEXEL flanged induction motor / IEC flanged induction motor
- Accessories Base & Foundation bolts (M12×160L×50b)

50Hz Performance Curve & Technical Data

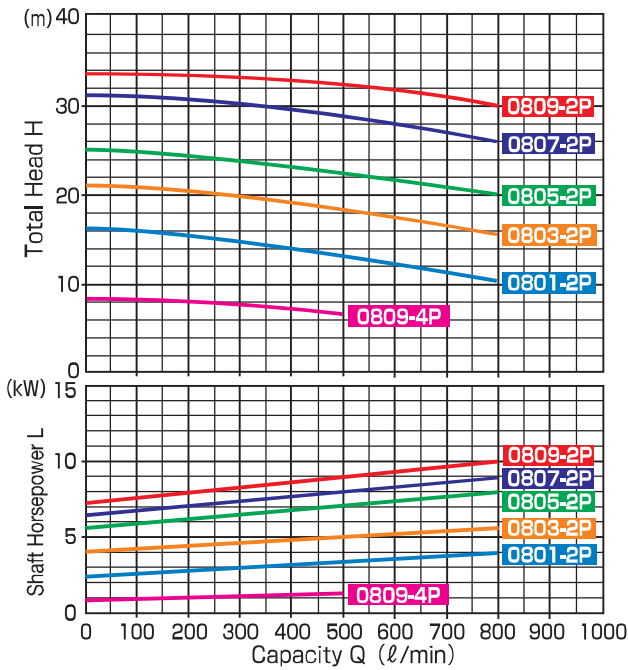

Model	Capacity (ℓ/min)	Total Head (m)	NPSH Re (m)	Motor Output (kW)
MES-0801-2P	800	10	5.0	1.5~18.5
MES-0803-2P		15		
MES-0805-2P		20		
MES-0807-2P		25		
MES-0809-2P		30		
MES-0809-4P	400	7.5	5.0	1.5~3.7

Note: NPSH Re values shown in the table are those obtained from the maximum suction pipe diameter.

60Hz Performance Curve & Technical Data

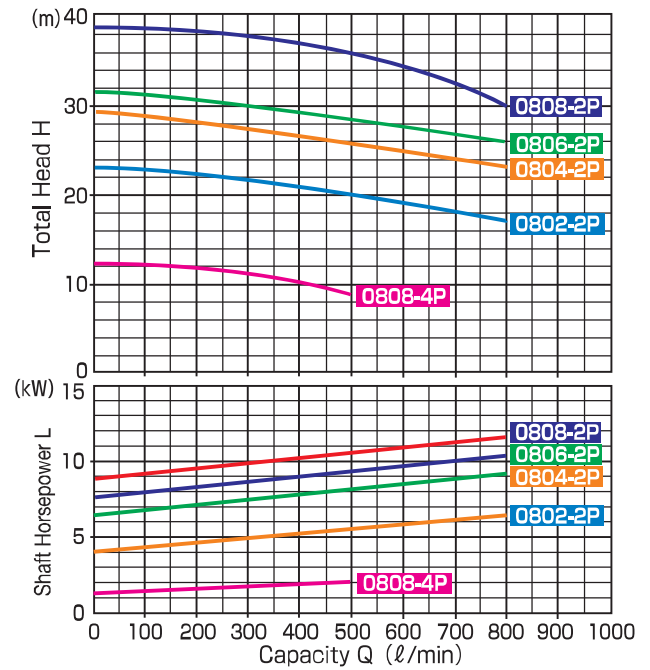

Model	Capacity (ℓ/min)	Total Head (m)	NPSH Re (m)	Motor Output (kW)
MES-0802-2P	800	17	6.5	1.5~18.5
MES-0804-2P		20		
MES-0806-2P		25		
MES-0808-2P		30		
MES-0808-4P	400	10	6.0	1.5~3.7

Note: NPSH Re values shown in the table are those obtained from the maximum suction pipe diameter.

Pump Identification

MES - 080 1 E 02 A C A 4

① ② ③④ ⑤ ⑥ ⑦⑧ ⑨

- ① Model ② Suction Pipe Size
- ③ Model Number Please refer to Performance Curve
- ④ Gasket Material E: EPDM (O-ring) and PTFE (Jacketed)
F: EPM (O-ring) and PTFE (Jacketed) Z: Other
- ⑤ Motor Output
02 : 1.5kW 03 : 2.2kW 05 : 3.7kW 07 : 5.5kW
10 : 7.5kW 15 : 11kW 20 : 15kW 25 : 18.5kW
- ⑥ Pump Body Material

Type	Casing/Tank	Shaft Support/Drain	Impeller+Inner Magnet	Rear Casing
A	G-Epoxy	PP	PFA	PFA + Eng.Plastic
C	C-Epoxy			
P	G-Epoxy	PVDF		
Z	Other Combinations or Special Option			

⑦ Motor Type

C: TEFC/outdoor TEXEL motor D: Explosion-proof increased safety (eG3) TEXEL motor
T: IEC standard explosion-proof (d2G4) motor

⑧ Material Combination

Type	Shaft	Front Thrust Ring	Rear Thrust Ring	Mouth Ring	Bearing
A(Standard)	Alumina-ceramic			C-PTFE	
B	SiC				
C	SiC			Carbon	
E	SiC			C-PTFE	
F	Alumina-ceramic			Carbon	
G	Alumina-ceramic			G-PTFE	
Z	Other Combinations or Special Option				

⑨ Number of Poles "4" is shown only when a 4-pole motor is installed.

Dimensions

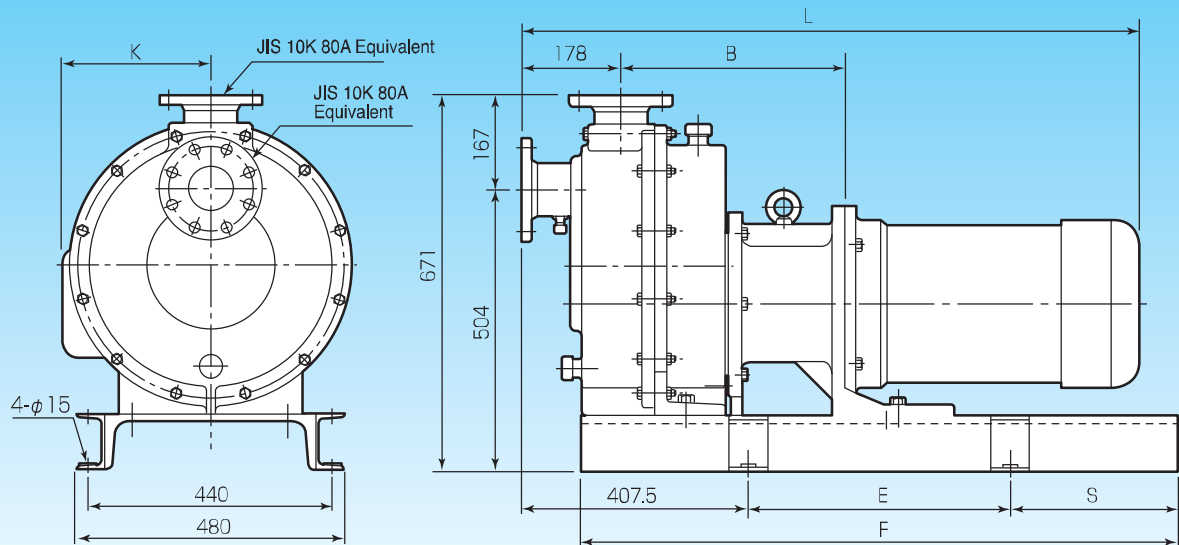

Motor Output (kW)	B	K	L	E	F	S	Weight (kg)
1.5 / 2.2	343	—	(810)	300	800	200	(135)
3.7	353	—	(845)				(137)
5.5 / 7.5	373	—	(952)	470	1070	300	(158)
11 / 15 / 18.5	403	(265)	(1110)				(166)

Note: ① The weight of pump does not include the motor weight.
 ② The dimensions shown above are applicable when a totally-enclosed fan-cooled 2-pole motor is used. When using special motors (such as explosion-proof motors), please contact us.
 ③ The figures in parentheses are reference values.

Construction Diagram

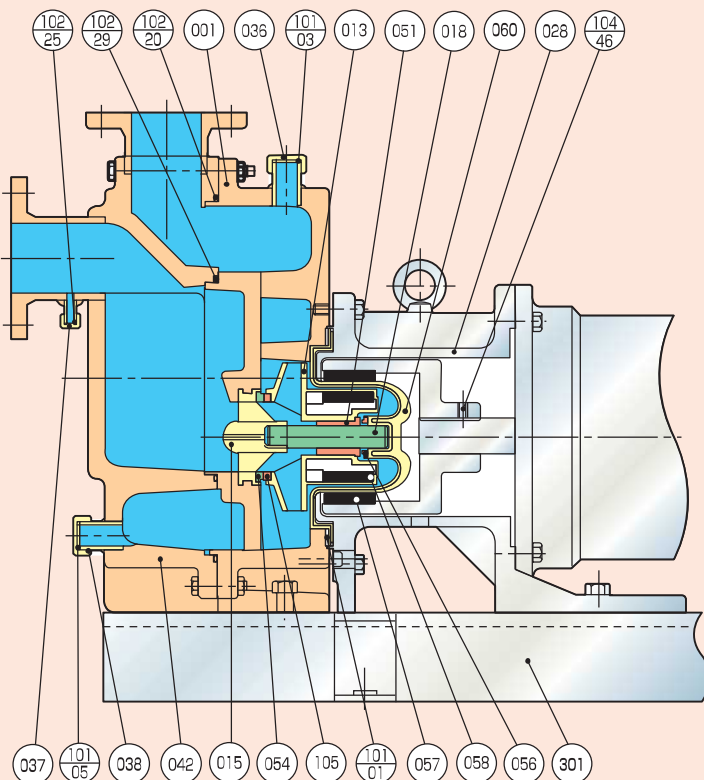

No.	Part Name	Materials
001	Casing	G-EA
		C-EA
013	Impeller + Magnet Lining	PFA
015	Shaft Support	PP / PVDF
018	Shaft	Alumina-ceramic / SiC
028	Bracket	FC200
036	Priming Plug	PP / PVDF
037	Air Vent Plug	PP / PVDF
038	Drain Plug	PP / PVDF
042	Tank	G-EA
		C-EA
051	Bearing	C-PTFE / SiC / Carbon / G-PTFE
054	Front Thrust Ring	Alumina-ceramic / SiC
056	Rear Thrust Ring	Alumina-ceramic / SiC
057	Outer Magnet	Rare Earth
058	Inner Magnet	Rare Earth
060	Rear Casing	PFA (Wetted Parts)
101-01	Casing Gasket	PTFE
101-03	Priming Plug Gasket	FPM / EPDM
101-05	Drain Plug Gasket	FPM / EPDM
102-20	O-ring(Tank)	FPM / EPDM
102-25	O-ring(Air Vent Plug)	FPM / EPDM
102-29	O-ring(Suction)	FPM / EPDM
104-46	Outer Magnet Set Screw	SNCM
105	Mouth Ring	C-PTFE / SiC / Carbon / G-PTFE
301	Base	SS400

Note: Inner Magnet (058) and Impeller (013) are integrated.



SEIKOW CHEMICAL ENGINEERING & MACHINERY, LTD.

Head Office 15-3 Minami Futami, Futami-cho, Akashi, Hyogo 674-0093
TEL: (078) 944-1840 FAX: (078) 944-1812

Export Division 5-14-10 Nishinakajima, Yodogawa-ku, Osaka 532-0011
TEL: (06) 7668-3500 FAX: (06) 7668-3431

URL <http://www.seikow.co.jp> E-mail texel@oak.ocn.ne.jp

Catalogue No.	
CP-60-MG2-E	
2111	F
R3.11.22.	