

# MTA-150 Series (Suction 150A × Discharge 125A)



## Pump Specifications

- Operating Temperature -20~100°C (Please consult us about 0°C below when used)
- Rotation Direction Clockwise (viewed from the motor)
- Flange JIS 10K RF (Please consult us about ANSI/DIN standard.)
- Finish Paint Munsell 2.5B4/8(pump body)
- Motor IEC flanged induction motor
- Accessories Base & Foundation bolts (M16×200L×63b)

### 50Hz Performance Curve & Technical Data

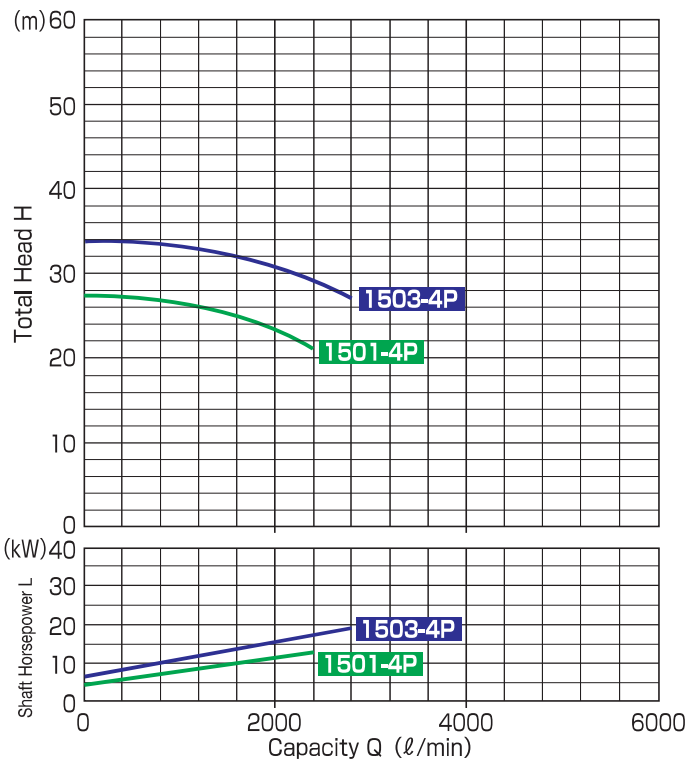

Model	Capacity (l/min)	Total Head (m)	NPSH Re (m)	Motor Output (kW)
MTA-1501-4P	2000	23	3.0	11~37
MTA-1503-4P		30		

Note: NPSH Re value shown in the table is that obtained from the maximum suction pipe diameter.

### 60Hz Performance Curve & Technical Data

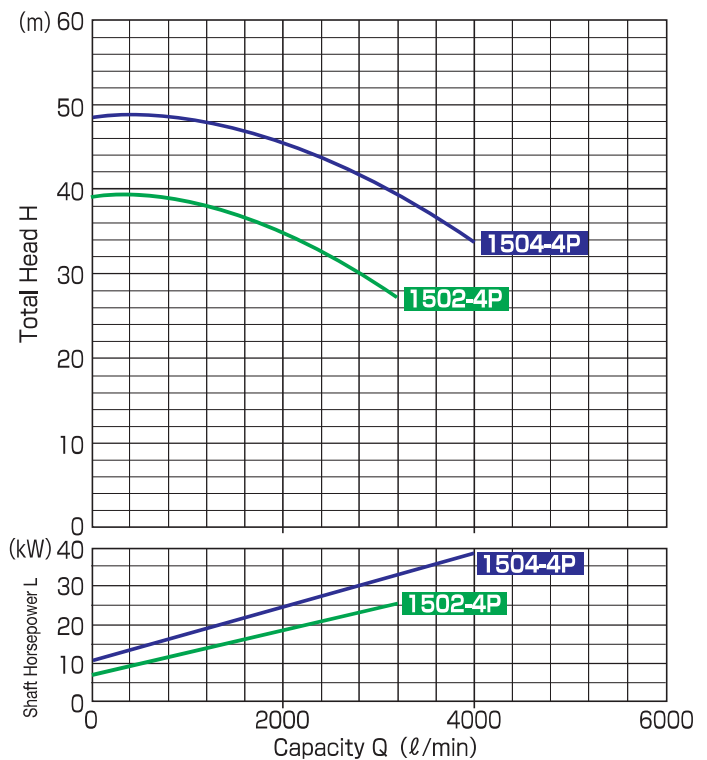

Model	Capacity (l/min)	Total Head (m)	NPSH Re (m)	Motor Output (kW)
MTA-1502-4P	2500	32	4.2	11~37
MTA-1504-4P	3000	40	5.5	

Note: NPSH Re values shown in the table are those obtained from the maximum suction pipe diameter.

## Pump Identification

**MTA-150 1 P 15 F A 4 L Z**

① ② ③ ④ ⑤ ⑥ ⑦ ⑧ ⑨ ⑩

- ① Model
- ② Suction Pipe Size
- ③ Model Number Please refer to Performance Curve
- ④ Gasket Material P : PTFE (Jacketed)
- ⑤ Motor Output 15:11kW 20:15kW 25:18.5kW  
30:22kW 40:30kW 50:37kW
- ⑥ Pump Body Material

Type	Casing	Impeller + Inner Magnet	Rear Casing
F		PFA	PFA + Eng. Plastic

### ⑦ Parts Material Combination

Type	Shaft	Front & Rear Thrust Rings	Mouth Ring & Bearing
A		Alumina-ceramic	C-PTFE
B		SiC	
C		SiC	Carbon
E		SiC	C-PTFE
F		Alumina-ceramic	Carbon
G		Alumina-ceramic	G-PTFE
H		SiC	G-PTFE
Z		Other Combinations or Special Option	

- ⑧ Number of Poles "4" is shown.
- ⑨ Construction Identification "L" is shown for long couplings only.
- ⑩ Custom Specifications "Z" is shown when non-standard parts are used.

Dimensions

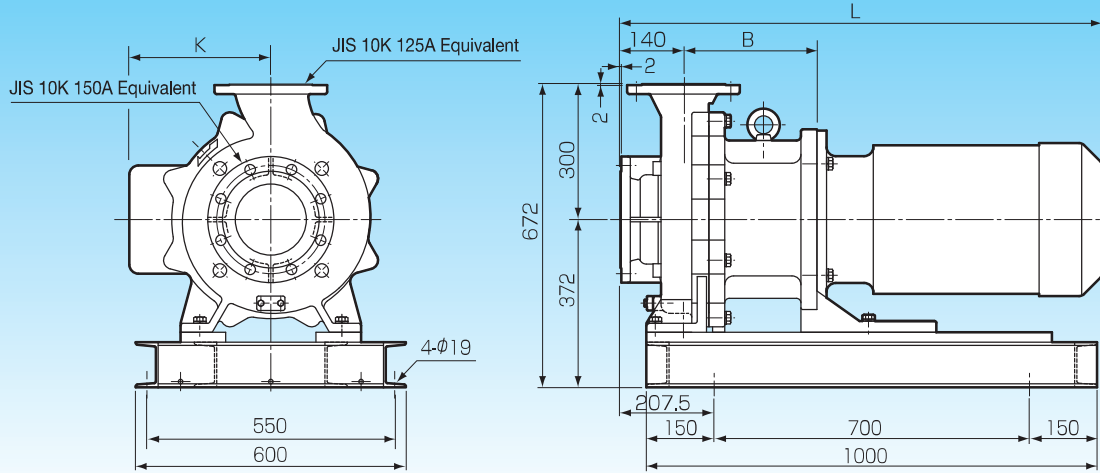

Motor Output (kW)	B	K	L	Weight (kg)
11~30	295.5	(314)	(1068.5)	(275)
37	325.5			

- Note: ① The weight of pump does not include the motor weight.  
 ② The dimensions shown above are applicable when a totally-enclosed fan-cooled motor is used. When using special motors (such as explosion-proof motors), please contact us.  
 ③ The figures in parentheses are reference values.

Construction Diagram

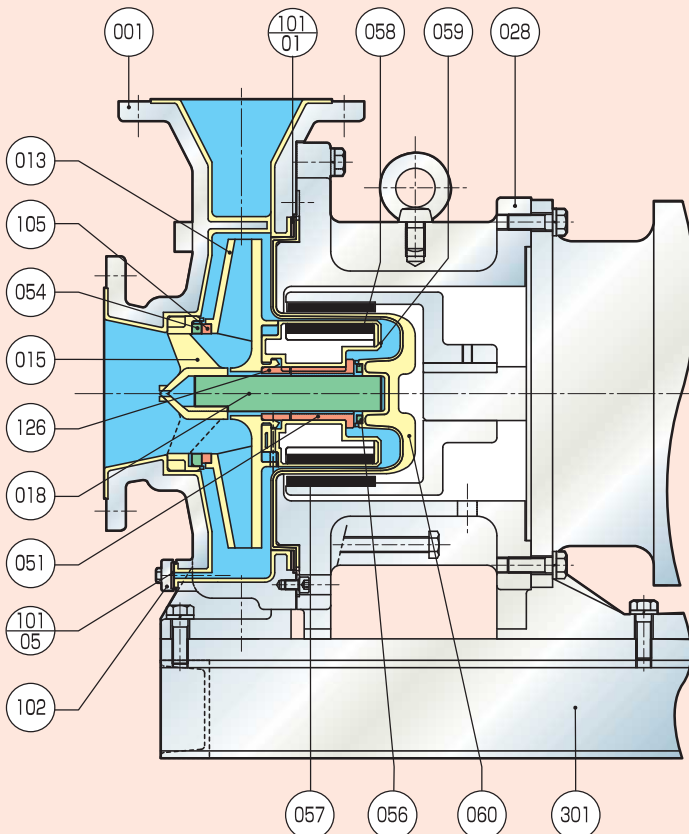

No.	Part Name	Materials
001	Casing	FCD450+PFA
013	Impeller	PFA
015	Shaft Support	PFA
018	Shaft	Alumina-ceramic / SiC
028	Bracket	FC200
051	Bearing	C-PTFE/G-PTFE/SiC/Carbon
054	Front Thrust Ring	Alumina-ceramic / SiC
056	Rear Thrust Ring	Alumina-ceramic / SiC
057	Outer Magnet	Rare Earth
058	Inner Magnet	Rare Earth
059	Magnet Lining	PFA
060	Rear Casing	PFA(Wetted Parts)
101-01	Casing Gasket	PTFE
101-05	Drain Gasket	PTFE(Jacketed)
102	Drain Flange	FC200
105	Mouth Ring	C-PTFE/G-PTFE/SiC/Carbon
126	Impeller Set Ring	PTFE
301	Base	SS400

Note: Inner Magnet (058) and Magnet Lining (059) are integrated and engaged with Impeller (013).