

# MTA-080 Series (Suction 80A × Discharge 50A)



## Pump Specifications

- Operating Temperature -20~120°C (Please consult us about 0°C below when used)
- Rotation Direction Clockwise (viewed from the motor)
- Flange JIS 10K RF (Please consult us about ANSI/DIN standard.)
- Finish Paint Munsell 2.5B4/8 (pump body)
- Motor IEC flanged induction motor
- Accessories Base & Foundation bolts (M12×160L×50b)

### 50Hz Performance Curve & Technical Data

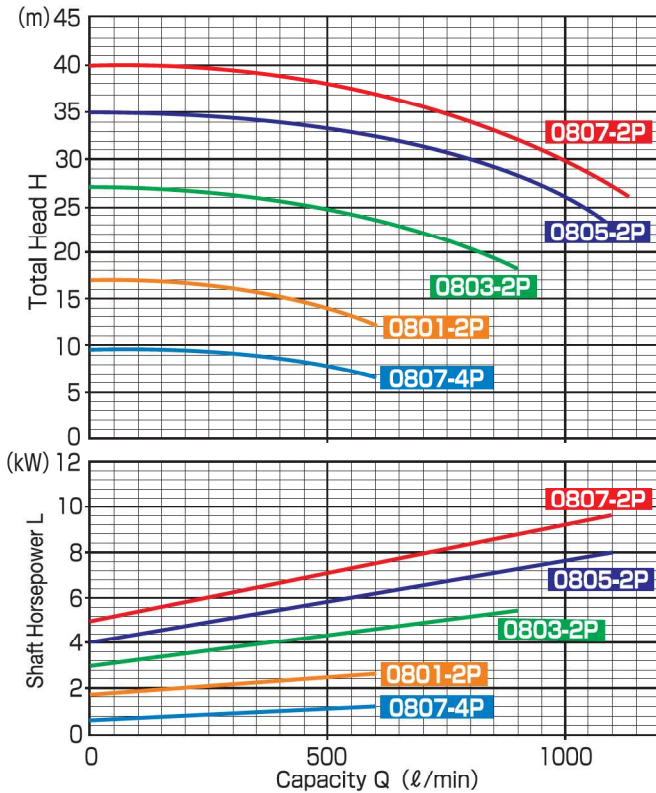

### 60Hz Performance Curve & Technical Data

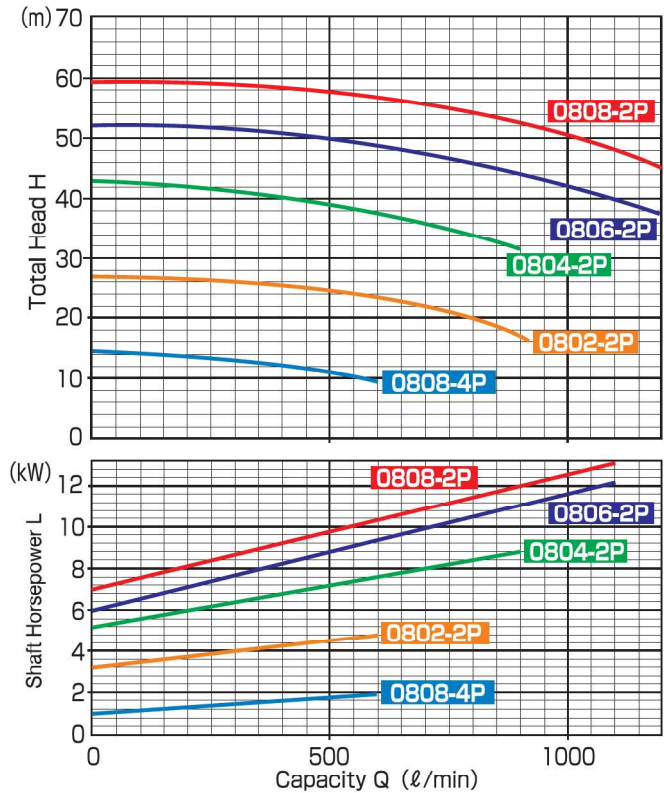

Model	Capacity (ℓ/min)	Total Head (m)	NPSH Re (m)	Motor Output (kW)
MTA-0801-2P	700	10	4.3	1.5~15
MTA-0803-2P	800	20	5.0	
MTA-0805-2P		30		
MTA-0807-2P	800	34	2.4	1.5~3.7
MTA-0807-4P		8		

Note: NPSH Re values shown in the table are those obtained from the maximum suction pipe diameter.

Model	Capacity (ℓ/min)	Total Head (m)	NPSH Re (m)	Motor Output (kW)
MTA-0802-2P	800	20	5.2	1.5~18.5
MTA-0804-2P		30		
MTA-0806-2P	1000	40	6.8	
MTA-0808-2P	1000	50	2.6	1.5~3.7
MTA-0808-4P		10		

Note: NPSH Re values shown in the table are those obtained from the maximum suction pipe diameter.

## Pump Identification

**MTA-080 1 P 02 F E 4**

① ② ③ ④ ⑤ ⑥ ⑦ ⑧

- ① Model
- ② Suction Pipe Size
- ③ Model Number Please refer to Performance Curve
- ④ Gasket Material P : PTFE (Jacketed)  
Z : Other
- ⑤ Motor Output 02 : 1.5kW 03 : 2.2kW 05 : 3.7kW  
07 : 5.5kW 10 : 7.5kW 15 : 11kW  
20 : 15kW 25 : 18.5kW(60Hz only)

### ⑥ Pump Body Material

Type	Casing	Impeller+ Inner Magnet	Rear Casing
F	PFA	PFA	PFA+Eng.Plastic
Z			Other Combinations or Special Option

### ⑦ Parts Material Combination

Type	Shaft	Front & Rear Thrust Rings	Mouth Ring & Bearing
B	SiC	SiC	Carbon
C			C-PTFE
E (Standard)			G-PTFE
H	SiC	SiC	Other Combinations or Special Option
Z			Other Combinations or Special Option

⑧ Number of Poles "4" is shown only when a 4-pole motor is installed.

**Dimensions**

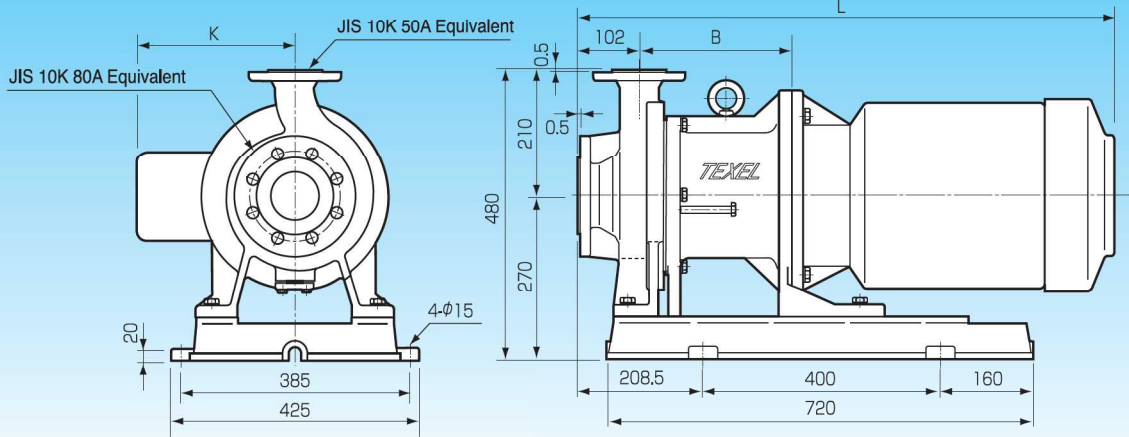

Motor Output (kW)	B	K	L	Weight (kg)
1.5 / 2.2	195	(260)	(895)	(108)
3.7	205			
5.5 / 7.5	225			
11 / 15 / 18.5	255			

Note: ① The weight of pump does not include the motor weight.  
 ② The dimensions shown above are applicable when a totally-enclosed fan-cooled 2-pole motor is used.  
 When using special motors (such as explosion-proof motors), please contact us.  
 ③ The figures in parentheses are reference values.

**Construction Diagram**

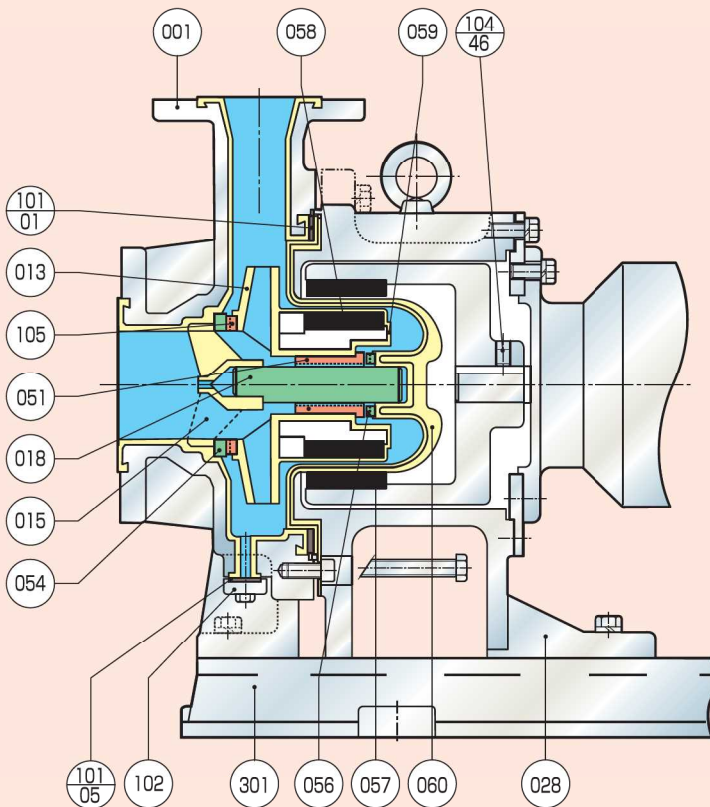

No.	Part Name	Materials
001	Casing	FCD450 + PFA
013	Impeller	PFA
015	Shaft Support	PFA
018	Shaft	SiC
028	Bracket	FC200
051	Bearing	C-PTFE / SiC / Carbon / G-PTFE
054	Front Thrust Ring	SiC
056	Rear Thrust Ring	SiC
057	Outer Magnet	Rare Earth
058	Inner Magnet	Rare Earth
059	Magnet Lining	PFA
060	Rear Casing	PFA (Wetted Parts)
101-01	Casing Gasket	PTFE (Jacketed)
101-05	Drain Gasket	PTFE (Jacketed)
102	Drain Flange	FC200
104-46	Outer Magnet Set Screw	SNCM
105	Mouth Ring	C-PTFE / SiC / Carbon / G-PTFE
301	Base	FC200

Note: Inner Magnet (058), Magnet Lining (059), and Impeller (013) are integrated.