

MSX-125 Series (Suction 125A × Discharge 100A)



Pump Specifications

- Operating Temperature -20~150°C (Please consult us about 0°C below and 100°C higher when used)
- Rotation Direction Clockwise (viewed from the motor)
- Flange JIS 10K RF (Please consult us about ANSI/DIN standard.)
- Finish Paint Munsell 2.5B4/8(pump body)
- Motor IEC flanged induction motor
- Accessories Base & Foundation bolts (M16×200L×63b)

50Hz Performance Curve & Technical Data

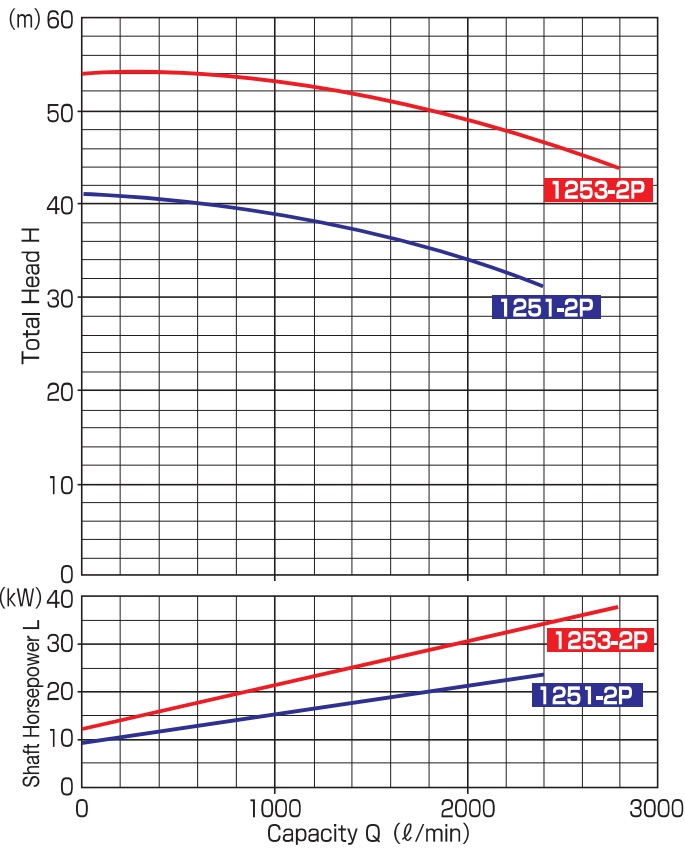

Model	Capacity (ℓ/min)	Total Head (m)	NPSH Re (m)	Motor Output (kW)
MSX-1251-2P	2000	30	5.0	11~30
MSX-1253-2P		40		

Note: NPSH Re value shown in the table is that obtained from the maximum suction pipe diameter.

60Hz Performance Curve & Technical Data

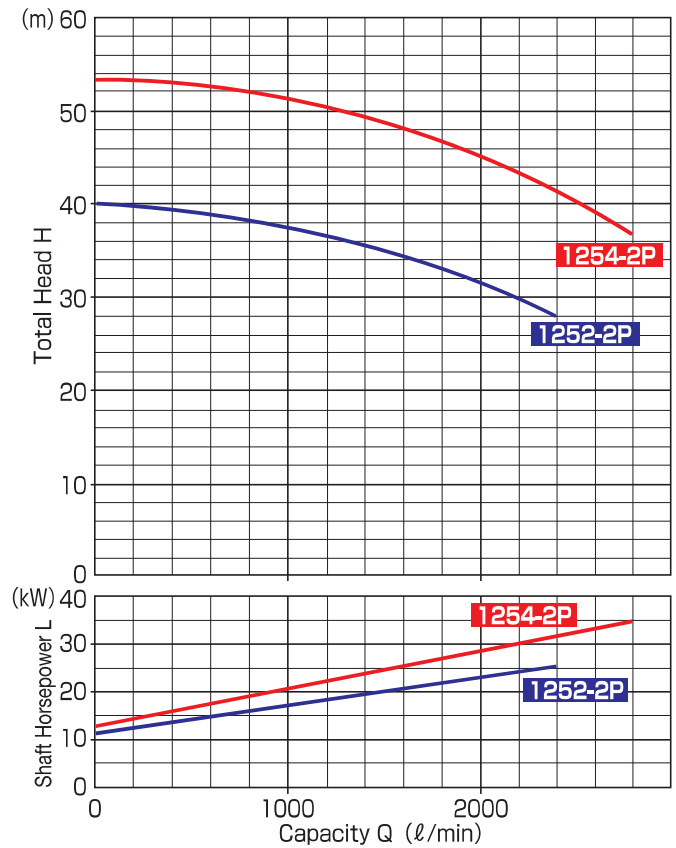

Model	Capacity (ℓ/min)	Total Head (m)	NPSH Re (m)	Motor Output (kW)
MSX-1252-2P	2000	30	6.5	11~37
MSX-1254-2P		40		

Note: NPSH Re value shown in the table is that obtained from the maximum suction pipe diameter.

Pump Identification

MSX-125 1 P 15 F A L

① ② ③ ④ ⑤ ⑥ ⑦ ⑧

- ① Model
- ② Suction Pipe Size
- ③ Model Number Please refer to Performance Curve
- ④ Gasket Material P : PTFE (Jacketed)
Z : Other
- ⑤ Motor Output 15 : 11kW 20 : 15kW 25 : 18.5kW
30 : 22kW 40 : 30kW 50 : 37kW
- ⑥ Pump Body Material

Type	Casing	Impeller+Inner Magnet	Rear Casing
F		PFA	PFA+PEEK
S		PFA	SiC
Z	Other Combinations or Special Option		

- ⑦ Parts Material Combination

Type	Shaft	Front Thrust Ring	Mouth Ring	Bearing
A(Standard)	SiC		C-PTFE	
B	SiC			
G	SiC		G-PTFE	
Z	Other Combinations or Special Option			

- ⑧ Construction Identification
"L" is shown for long couplings only.

Dimensions

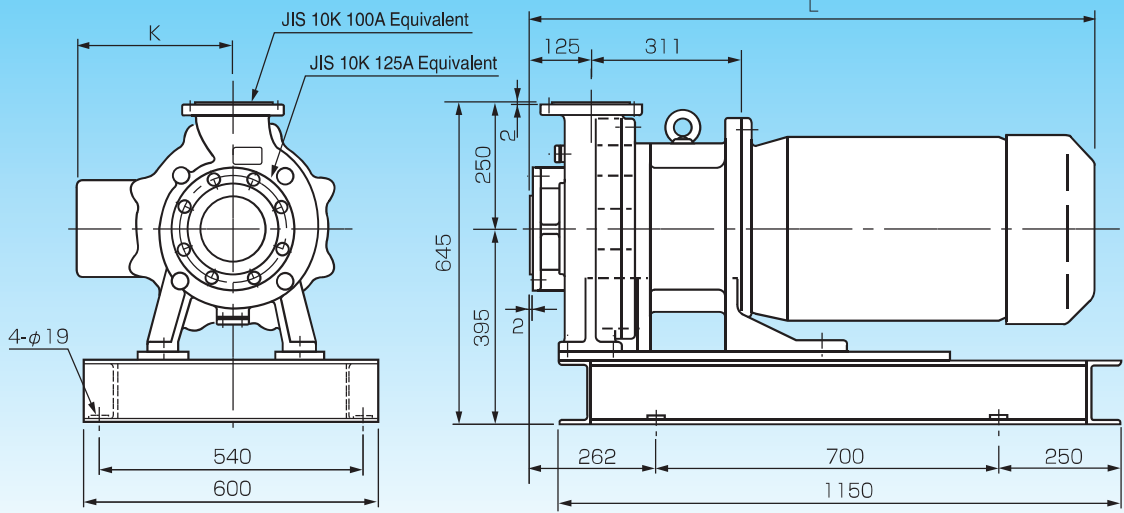

Motor Output (kW)	K	L	Weight (kg)
11~37	(330)	(1200)	(300)

- Note: ① The weight of pump does not include the motor weight.
 ② The dimensions shown above are applicable when a totally-enclosed fan-cooled motor is used.
 When using special motors (such as explosion-proof motors), please contact us.
 ③ The figures in parentheses are reference values.

Construction Diagram

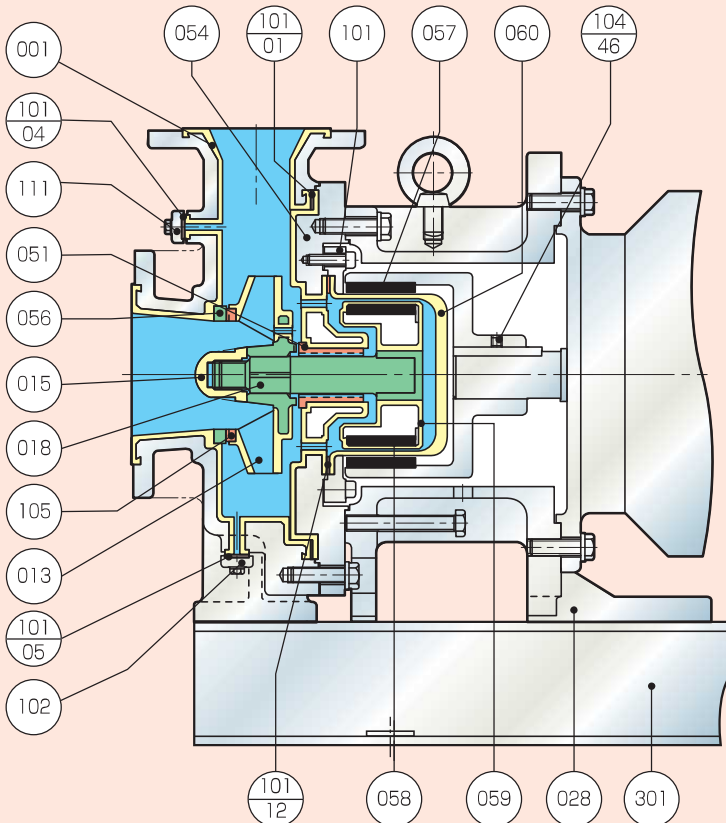

No.	Part Name	Materials
001	Casing	FCD450 + PFA
013	Impeller	PFA + SiC
015	Impeller Nut	C-PTFE
018	Shaft	SiC
028	Bracket	FC200
051	Bearing	C-PTFE / SiC / G-PTFE
054	Bearing Plate	FCD450 + PFA
056	Front Thrust Ring	SiC
057	Outer Magnet	Rare Earth
058	Inner Magnet	Rare Earth
059	Magnet Lining	PFA
060	Rear Casing	PFA(Wetted Parts) / SiC
101	Rear Casing Ring	SUS304
101-01	Casing Gasket	PTFE
101-04	Air Vent Gasket	PTFE(Jacketed)
101-05	Drain Gasket	PTFE(Jacketed)
101-12	Rear Casing Gasket	PTFE(Jacketed)
102	Drain Flange	FC200
104-46	Outer Magnet Set Screw	SNCM
105	Mouth Ring	C-PTFE / SiC / G-PTFE
111	Air Vent Flange	FC200
301	Base	SS400

Note: Inner Magnet (058) and Magnet Lining (059) are integrated.